



[DBPR HOME](#) |
 [ABOUT DBPR](#) |
 [DBPR DIVISIONS](#) |
 [CONTACT DBPR](#)



[BCIS Home](#) |
 [Log In](#) |
 [User Registration](#) |
 [Hot Topics](#) |
 [Submit Surcharge](#) |
 [Stats & Facts](#) |
 [Publications](#) |
 [FBC Staff](#) |
 [BCIS Site Map](#) |
 [Links](#) |
 [Search](#)



Product Approval
USER: Public User

License efficiently. Regulate fairly.

[Product Approval Menu](#) >
 [Product or Application Search](#) >
 [Application List](#) >
 Application Detail

OFFICE OF THE SECRETARY

FL #	FL18429								
Application Type	New								
Code Version	2014								
Application Status	Approved								
	*Approved by DBPR. Approvals by DBPR shall be reviewed and ratified by the POC and/or the Commission if necessary.								
Comments									
Archived	<input type="checkbox"/>								
Product Manufacturer	La Finestra, LC								
Address/Phone/Email	2790 NW 104th Court Miami, FL 33172 (305) 599-8093 brunosalvoni@lafinestra.us								
Authorized Signature	William Cook willycook@bromleycook.com								
Technical Representative									
Address/Phone/Email									
Quality Assurance Representative									
Address/Phone/Email									
Category	Exterior Doors								
Subcategory	Swinging Exterior Door Assemblies								
Compliance Method	Evaluation Report from a Florida Registered Architect or a Licensed Florida Professional Engineer <input type="checkbox"/> Evaluation Report - Hardcopy Received								
Florida Engineer or Architect Name who developed the Evaluation Report	William D. Cook								
Florida License	PE-43904								
Quality Assurance Entity	National Accreditation & Management Institute								
Quality Assurance Contract Expiration Date	04/30/2018								
Validated By	Frank L. Bennardo, P.E. <input checked="" type="checkbox"/> Validation Checklist - Hardcopy Received								
Certificate of Independence	FL18429_R0_COI_Certificate of Independence for ECU-53 OS Door.pdf								
Referenced Standard and Year (of Standard)	<table border="0"> <thead> <tr> <th>Standard</th> <th>Year</th> </tr> </thead> <tbody> <tr> <td>TAS 201-94</td> <td>1994</td> </tr> <tr> <td>TAS 202-94</td> <td>1994</td> </tr> <tr> <td>TAS 203-94</td> <td>1994</td> </tr> </tbody> </table>	Standard	Year	TAS 201-94	1994	TAS 202-94	1994	TAS 203-94	1994
Standard	Year								
TAS 201-94	1994								
TAS 202-94	1994								
TAS 203-94	1994								
Equivalence of Product Standards Certified By	Approved Testing Lab FL18429_R0_Equiv_EQUIVALENCY LETTER-AAMA 501.pdf								
Sections from the Code									

Product Approval Method Method 1 Option D

Date Submitted 08/28/2015

Date Validated 02/12/2016

Date Pending FBC Approval

Date Approved 02/14/2016

Summary of Products

FL #	Model, Number or Name	Description
18429.1	EKU-53 Outswing French Door	EKU-53 Outswing French Door (LMI + SMI)
Limits of Use Approved for use in HVHZ: Yes Approved for use outside HVHZ: Yes Impact Resistant: Yes Design Pressure: +110/-110 Other:		Installation Instructions FL18429_R0_II_PRODUCT APPROVAL EKU 53 OUTSWING DOOR DWGS.pdf Verified By: William D. Cook 43904 Created by Independent Third Party: Yes Evaluation Reports FL18429_R0_AE_EVALUATION REPORT EKU-53 Door 2016-02-12.pdf Created by Independent Third Party: Yes

[Back](#) [Next](#)

[Contact Us](#) :: 2601 Blair Stone Road, Tallahassee FL 32399 Phone: 850-487-1824

The State of Florida is an AA/EEO employer. [Copyright 2007-2013 State of Florida.](#) :: [Privacy Statement](#) :: [Accessibility Statement](#) :: [Refund Statement](#)

Under Florida law, email addresses are public records. If you do not want your e-mail address released in response to a public-records request, do not send electronic mail to this entity. Instead, contact the office by phone or by traditional mail. If you have any questions, please contact 850.487.1395. *Pursuant to Section 455.275(1), Florida Statutes, effective October 1, 2012, licensees licensed under Chapter 455, F.S. must provide the Department with an email address if they have one. The emails provided may be used for official communication with the licensee. However email addresses are public record. If you do not wish to supply a personal address, please provide the Department with an email address which can be made available to the public. To determine if you are a licensee under Chapter 455, F.S., please click [here](#).

Product Approval Accepts:



**CERTIFICATE OF INDEPENDENCE FOR FLORIDA PRODUCT
APPROVAL**

Product Approval Submittal
Department of Community Affairs
Florida Building Code Online
Codes and Standards
2555 Shumard Oak Boulevard
Tallahassee, Fl 32399

August 28, 2015

MANUFACTURER:

La Finestra LC
2790 NW 104th Court
Miami, Fl. 33172

PRODUCT:

EKU-53 Outswing French Door
Large & Small Missile Impact

To Whom It May Concern,

This statement from this Firm certifies that we have no financial interest with the laboratory that performs the test, nor the engineer witnessing and sealing the test and test report as a laboratory representative. This pertains to the La Finestra product approval submittal.

For further questions please call this Firm.

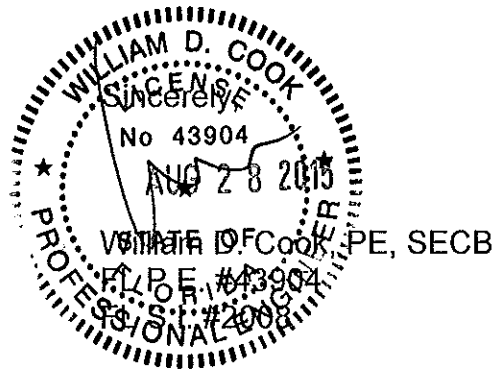

TESTING EQUIVALENCY LETTER

Florida Department of Business & Professional Regulation
Building Codes and Standards
1940 North Monroe Street,
Tallahassee, Florida 32399

August 28, 2015

MANUFACTURER:
La Finestra LC
2790 NW 104th Court
Miramar, Fl. 33172

PRODUCT:
La Finestra
EKU-53 Product Line

To Whom It May Concern,

We are submitting the La Finestra EKU-53 line of glazing products for Florida Product approval.

Previously, these products were approved under the Miami Dade NOA approval and three bays were tested under protocols of TAS 201-94, TAS 202-94, and TAS 203-94.

Please be advised that TAS 202-94 is more stringent than AAMA 501-94 and therefore this product complies with AAMA 501-94 as follows:

The AAMA 501-94 series of tests assesses the products in this order:

- 1) Air Leakage,
- 2) Water Penetration,
- 3) Structural Performance.

While the TAS 202-94 testing protocol is ordered:

- 1) Air Leakage,
- 2) Structural Performance,
- 3) Water Penetration.

The TAS 202-94 protocol tests for water intrusion after the structural performance test allowing for assessment of the product at a more compromised state than the AAMA 501-94 protocol. Under scrutiny the TAS 202-94 is an equivalent to AAMA 501-94 if not more stringent, and satisfies the purposes of the AAMA 501-94 protocol.

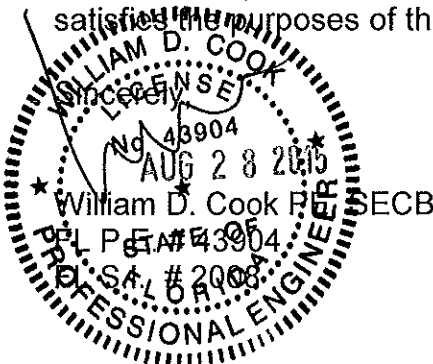

PRODUCT EVALUATION REPORT

EKU-53 OUTSWING ALUMINUM FRENCH DOOR:

Product: FL18429.1
EKU-53 Outswing Aluminum French Door
Large Missile Small Impact Resistant.

Manufacturer: La Finestra
2790 N.W. 104 Court
Miami, FL 33172
(305) 599-8093

Statement of Compliance: This report evaluates the above-listed product per the requirements of FAC Product Approval Rule Chapter 9N-3.005 (4), using 9N-3.005 Method 1-D (Engineering Evaluation). This product complies with the requirements of the Florida Building Code both inside and outside of the High Velocity Hurricane Zone. The product testing standards performed are outlined below.

Technical Documentation:

- 1) Installation Drawings **FN-EKU53-FD**, Signed and Sealed by William D. Cook, P.E. on 08/28/2015.

- 2) Testing to TAS 201, TAS 202, and TAS 203 from
 - Hurricane Engineering & Testing Inc. 6120 NW 104 Court, Doral, Florida 33178, Test Reports No.: **HETI-08-2005**, **HETI-08-2020**, **HETI-08-2163**, **HETI-08-2076A**, **HETI-11-3365** all dated 10/31/2008, all Signed and Sealed by Candido Font, P.E.,
 - Hurricane Engineering & Testing Inc. 6120 NW 104 Court, Doral, Florida 33178, Test Reports No.: **HETI-09-2627**, **HETI-09-2677**, **HETI-10-3002**, **HETI-10-3003**, **HETI-10-3009**, **HETI-10-3010** all dated 04/06/2010, all Signed and Sealed by Candido Font, P.E.,
 - Fenestration Testing Laboratory, Inc. 1677 West 31st Place, Hialeah, Florida 33012, Test Reports No. **FTL-4531**, dated 07/11/05 and Test Report No. **FTL-3881** dated 10/18/04, both signed and sealed by Edmundo Largaespada, P.E.

- 3) Supplemental Calculations to support **FN-EKU53-FD**, signed and sealed by William D. Cook, P.E.

Bromley • Cook | ENGINEERING

STRUCTURAL ENGINEERING SERVICES

5440 N.W. 33rd Avenue
Suite 100
Fort Lauderdale, Fl. 33309
tel: 954-772-4624
fax: 954-772-4634

Limitations of Use for this product:

- See Installation Drawings FN-EKU53-FD for approved anchor methods and spacing.
- Product is impact rated and does not require the use of shutters in windborne debris regions.
- May be used inside and outside the High Velocity Hurricane Zone.
- See Installation Drawings FN-EKU53-FD for size and design pressure limitations

Certification of Independence: Bromley-Cook Engineering and William D. Cook, P.E. do not have nor will acquire financial interest in the company manufacturing or distributing the product or in any other entity involved in the approval process of the product named in this evaluation report.

For further questions please contact this firm.

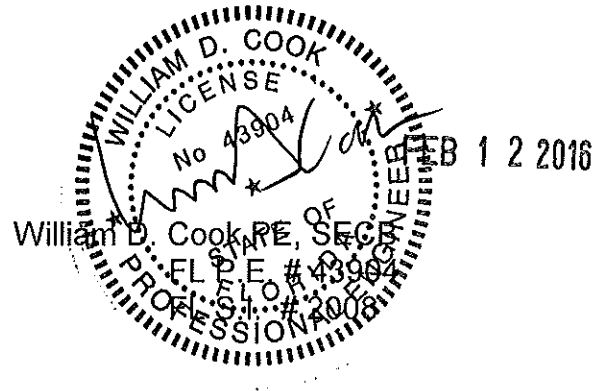

LA FINESTRA, LC SERIES: EKU 53 OUTSWING FRENCH DOOR (HIGH LOAD)

TYPICAL UNIT ELEVATIONS

MAX. DOOR SIZES SHOWN
 MULTIPLE UNITS STACKED SIDE BY SIDE
 MUST HAVE APPROVED MULLIONS BETWEEN EACH WINDOW FRAME
 *(SEE ALTERNATE CONFIGURATIONS ON PAGE 2)

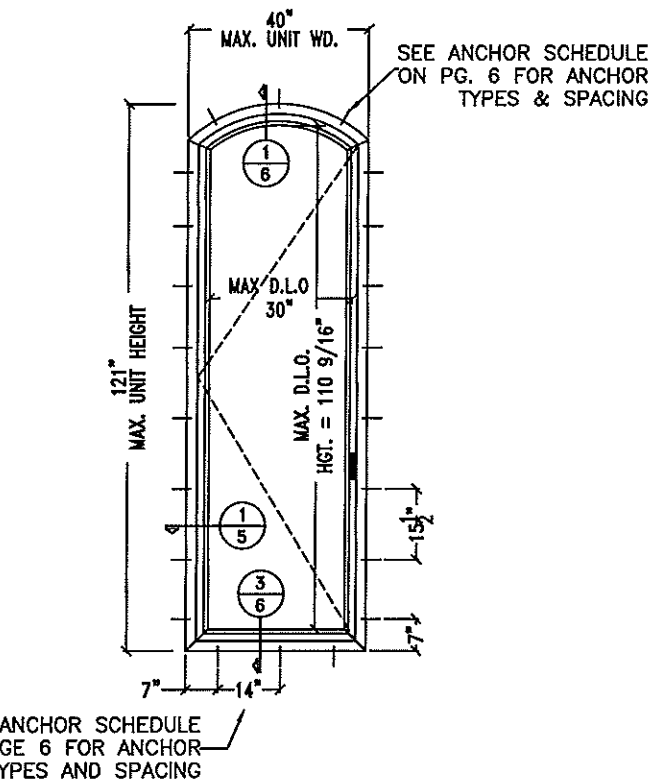
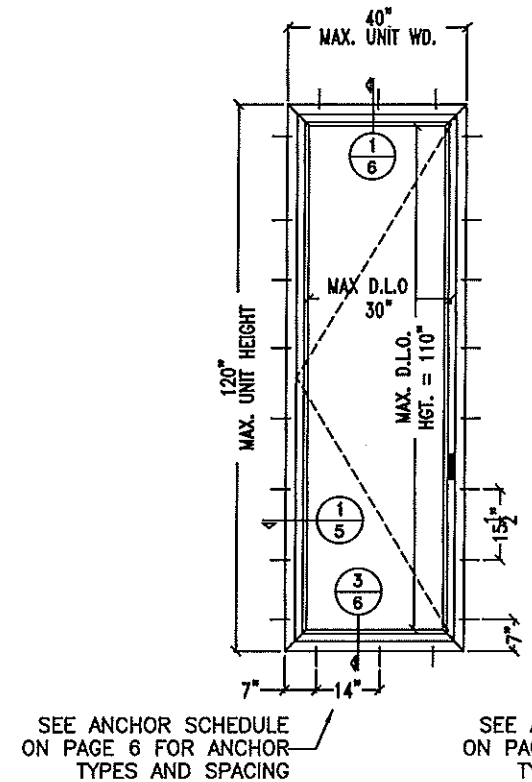
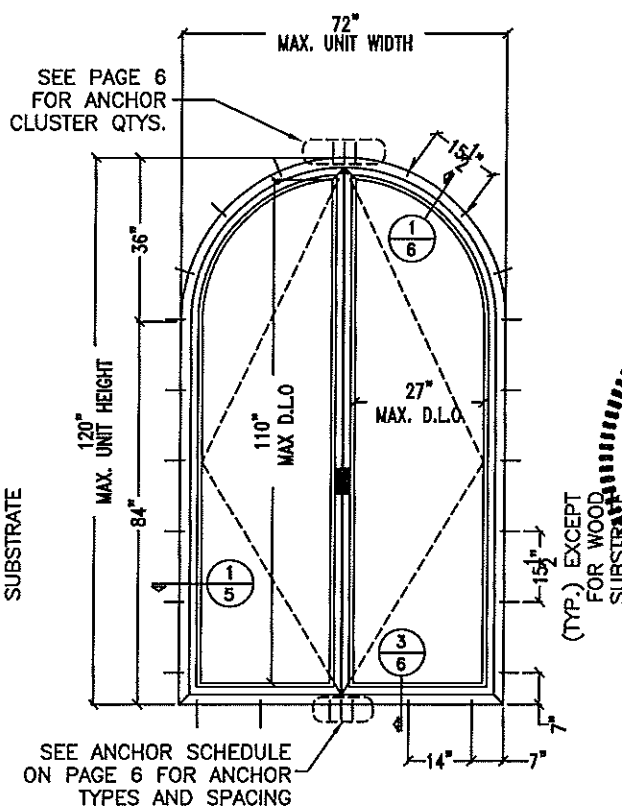
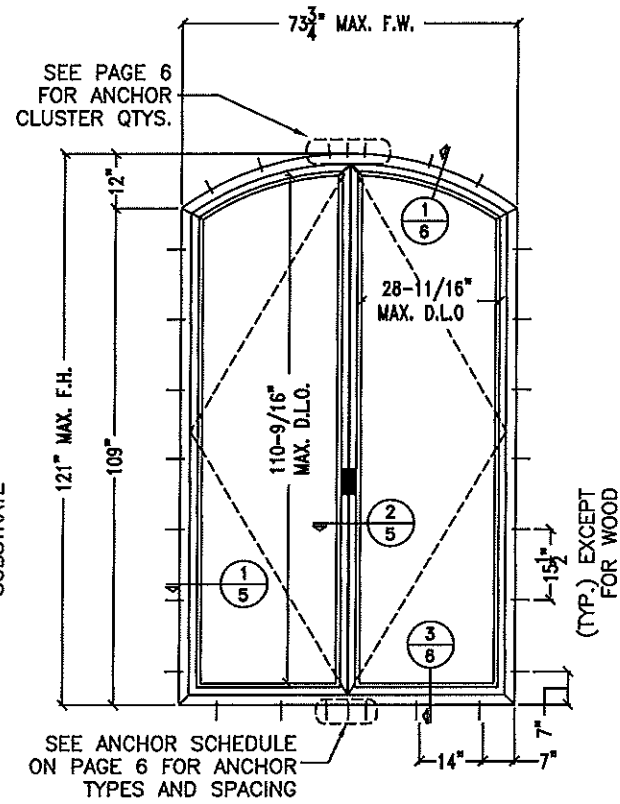
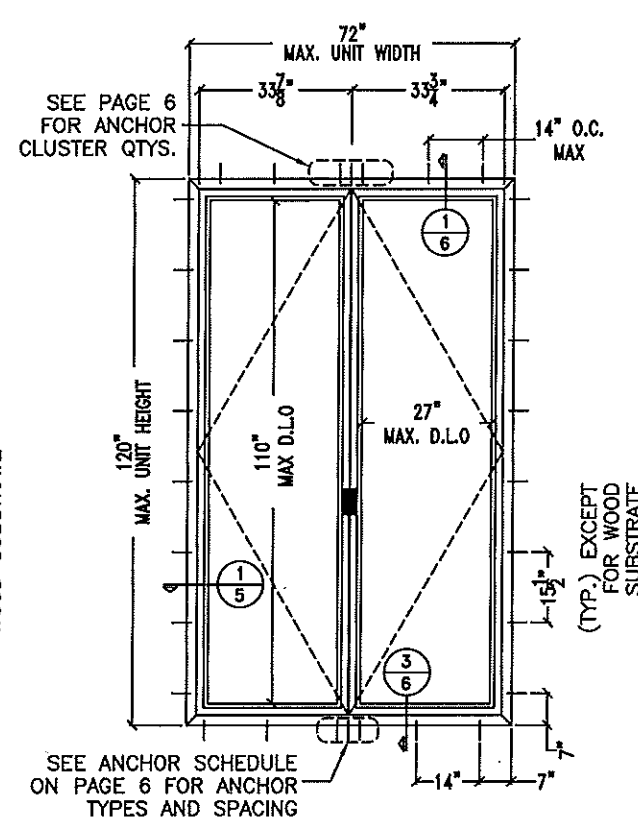
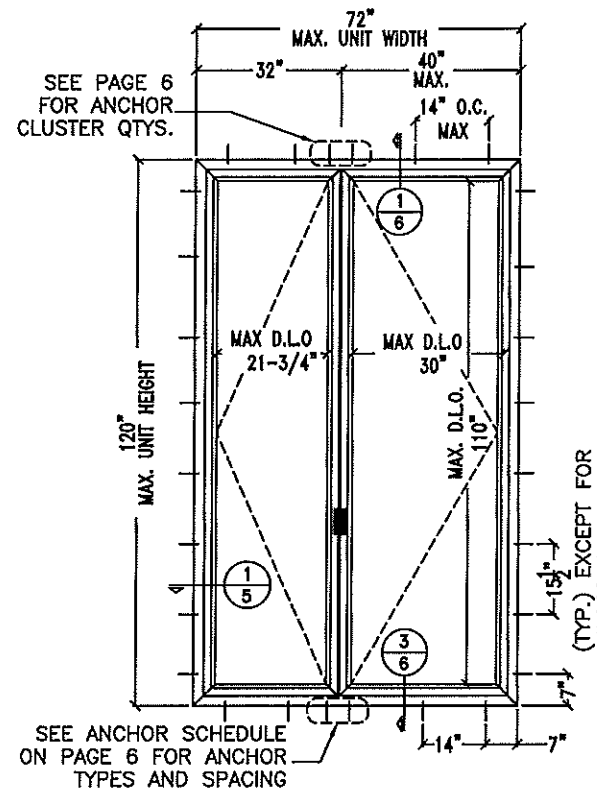

NOTES:

1. THIS SYSTEM HAS BEEN DESIGNED TO COMPLY WITH THE REQUIREMENTS OF THE HIGH VELOCITY HURRICANE ZONE AS DESCRIBED IN THE FLORIDA BUILDING CODE 5TH EDITION (2014)
2. THIS WINDOW SYSTEM HAS BEEN TESTED, ENGINEERED AND APPROVED FOR DESIGN PRESSURES NOT TO EXCEED THOSE SHOWN IN SCHEDULE.
3. BUCK, OPENINGS & BUCK FASTENERS MUST BE DESIGNED & INSTALLED TO WITHSTAND WIND LOADS FOR EACH APPLICATION. THE DESIGN & ENGINEERING OF BUCKS SHALL BE PROVIDED BY "THE ENGINEER OF RECORD"
4. BUCK FASTENERS MAY NOT EXCEED 16" O.C. SPACING AROUND OPENINGS.
5. THE SYSTEM SHOWN HEREIN WAS TESTED FOR WATER, AIR, IMPACT, CYCLIC & UNIFORM STATIC AIR PRESSURE TESTING IN CONFORMANCE WITH DADE COUNTY PROTOCOLS TAS-201, 202 & 203.
6. ONE-THIRD INCREASE IN ALLOWABLE MATERIAL STRESS LIMITS FOR SHORT DURATION WIND LOAD NOT USED IN THE DESIGN CALCULATIONS. EXCEPT 1.6 WINDLOAD FACTOR FOR WOOD.

SEE PAGE 4 FOR ALLOWABLE WIND PRESSURES AND GLASS CHART.

LA FINESTRA, L.C.
 ITALIAN WINDOWS & DOORS
 2790 Northwest 104th Court
 Miami, FL 33172-2175
 Phone (305) 599-8093
 Fax (305) 592-4671

PROFESSIONAL ENGINEER
 WILLIAM D. COOK
 LICENSE NO. 15000
 STATE OF FLORIDA
 AUG 28 2014

PRODUCT:
 EKU-53
 IMPACT DOORS
 HIGH LOAD

REVISIONS	DATE	BY	DESCRIPTION
No.			

DATE: 10/16/2014
 SCALE: 3/8" = 1'-0"
 DWG. BY: LA FIN
 CHK. BY:

DRAWING No.:
 FN-EKU53-FD
 SHEET: 1 OF 15

ALTERNATE CONFIGURATIONS

UNITS MAY BE INSTALLED WITH A MIAMI-DADE COUNTY APPROVED MULLION BETWEEN EACH DOOR AND/OR FRAME. THE LOWEST DESIGN PRESSURE FOR THE DOOR, TRANSOM OR MULLION WILL CONTROL

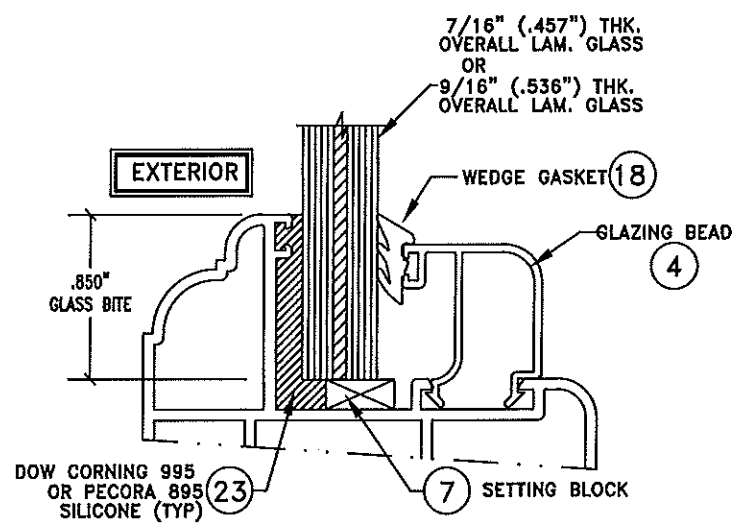
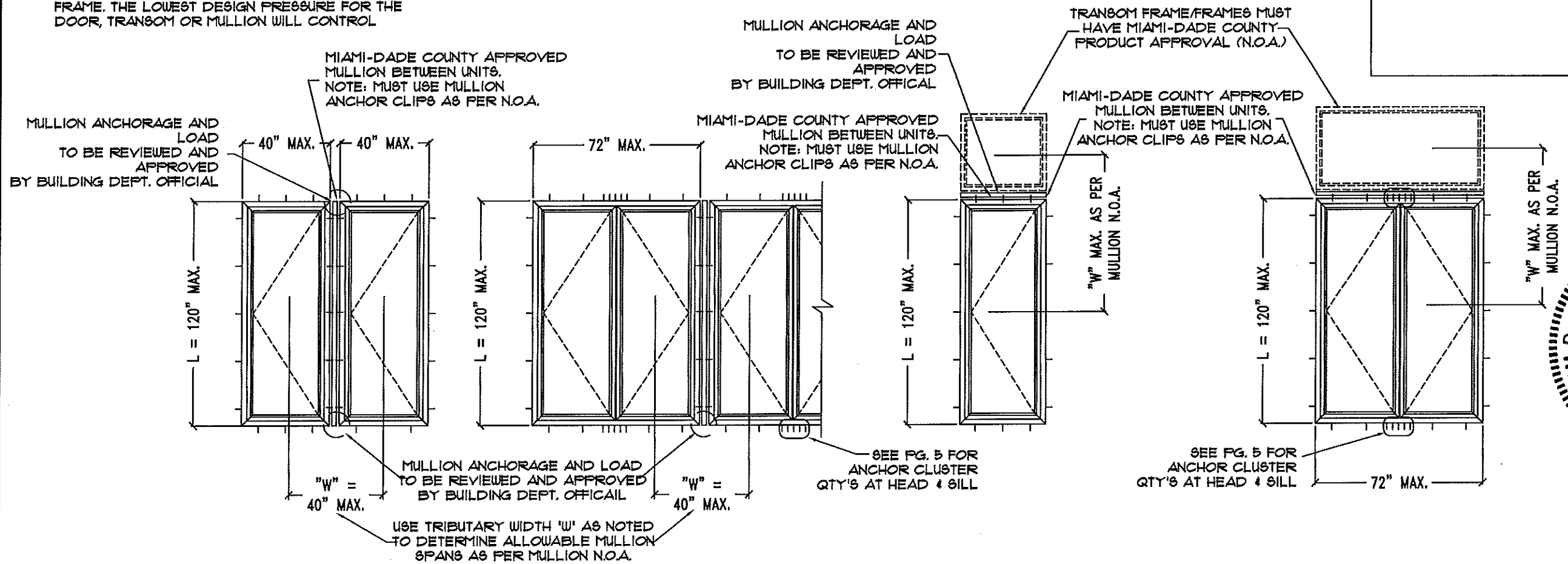

GLAZING DETAIL
GL-1, GL-3 THRU GL-8 (LAMINATED)
 SCALE: N.T.S.

NOTE: SEE ALLOWABLE D.L.O. SCHEDULE ON PG. 4 FOR MAX. DESIGN PRESSURES

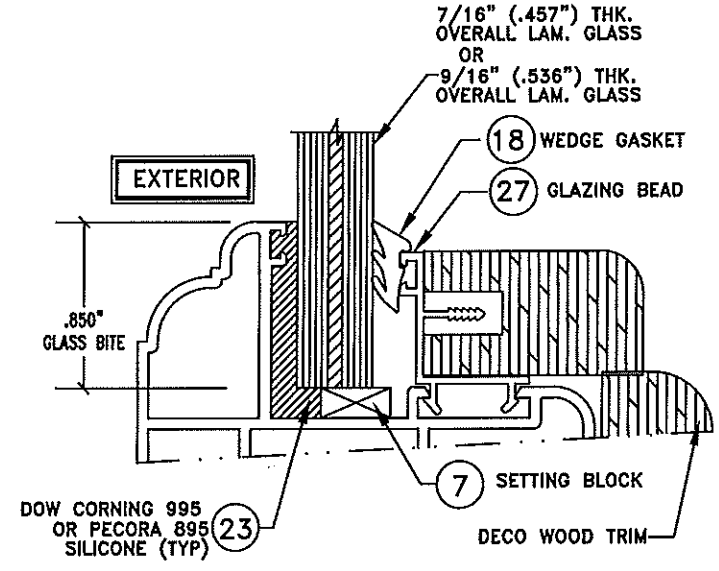

"OPTIONAL" GLAZING DETAIL GL-1 (WITH WOOD TRIM)
 SCALE: N.T.S.

NOTE: MAX. DESIGN PRESSURE = +80, -80 P.S.F.

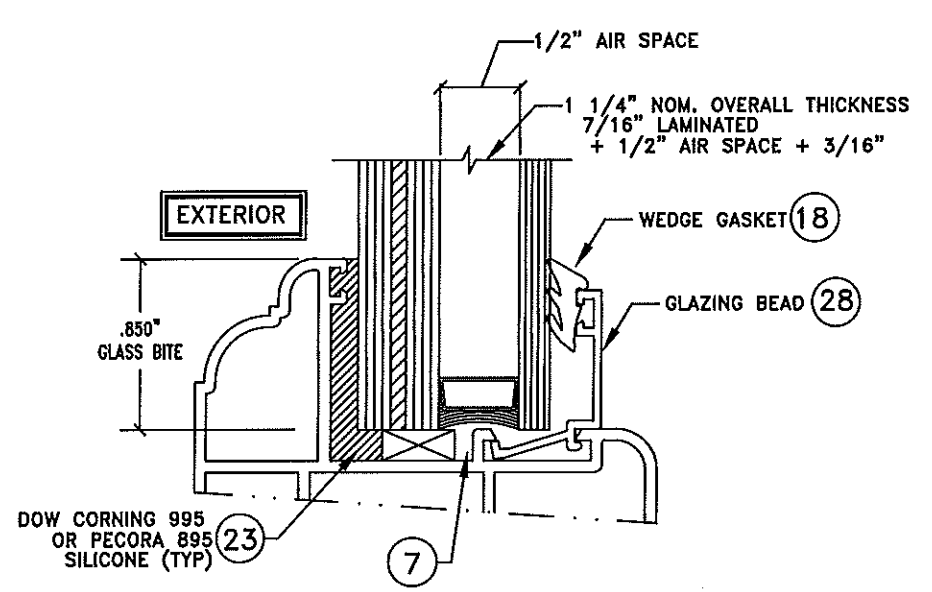

GLAZING DETAIL GL-2 (LAMINATED/INSULATED)
 SCALE: N.T.S.

NOTE: MAX. DESIGN PRESSURE = +80, -80 P.S.F.

LA FINESTRA, L.C.
 ITALIAN WINDOWS & DOORS
 2790 Northwest 104th Court
 Miami, FL 33172-2175
 Phone (305) 599-8093
 Fax (305) 592-4671

WILLIAM D. COOK ENGINEERING, INC.
 STRUCTURAL ENGINEERING SERVICES
 240 N.W. 33RD AVENUE SUITE #90
 FORT LAUDERDALE, FL 33308
 P.O. BOX 282015
 STATE OF FLORIDA
 PROFESSIONAL ENGINEER
 WILLIAM D. COOK, P.E. #4680

PRODUCT:
EKU-53
IMPACT DOORS
HIGH LOAD

REVISIONS	DATE	BY	DESCRIPTION
No.			

DATE: 10/16/2014
 SCALE: N/A
 DWG. BY: LA FIN
 CHK. BY:

DRAWING No.:
FN-EKU53-FD

SERIES EKU-53 ALUMINUM OUTSWING DOOR (UNIT ELEVATIONS VIEWED FROM EXTERIOR)

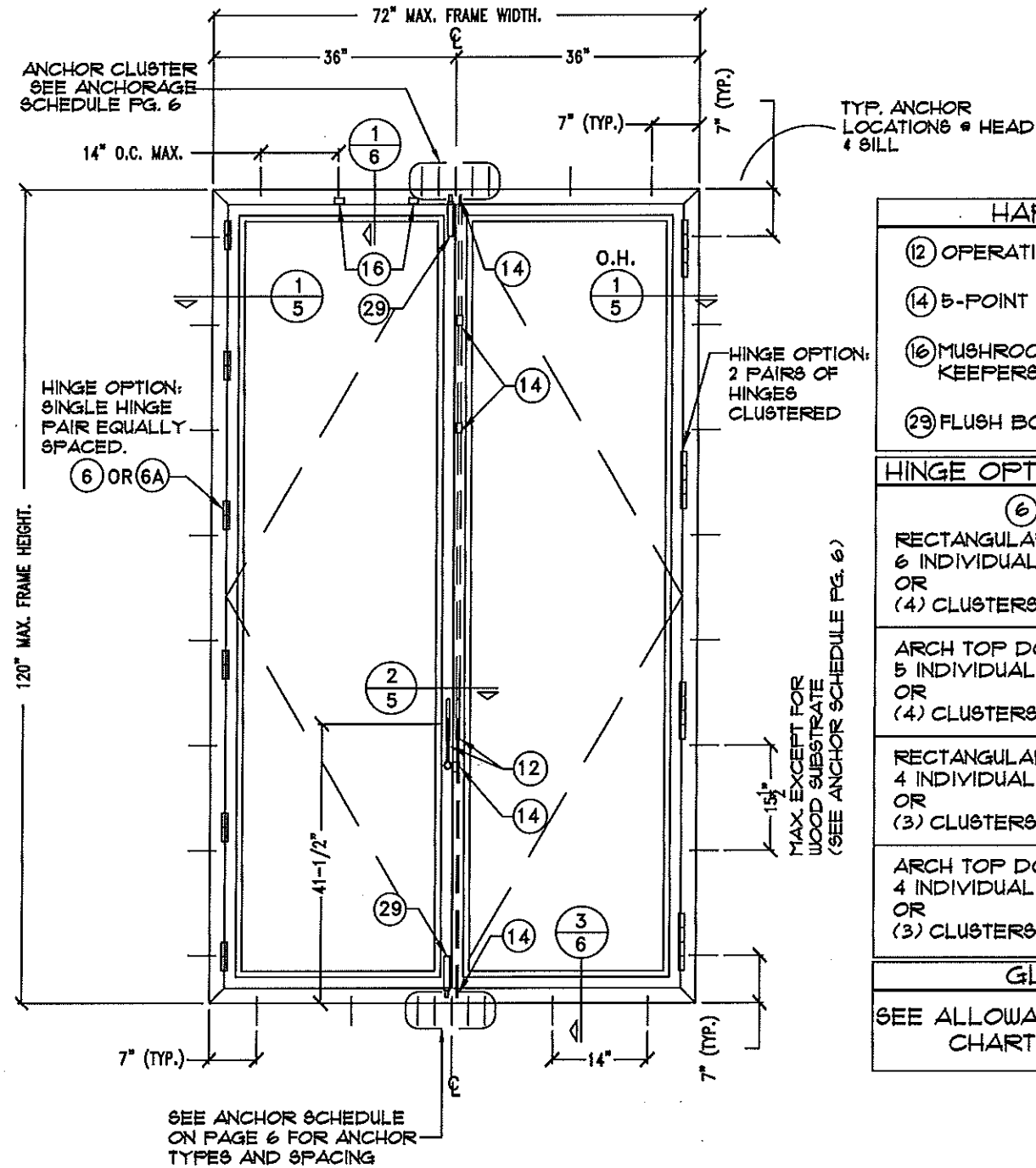

NOTE: FOR ODD NUMBER OF ANCHORS IN CLUSTER, INSTALL ONE ANCHOR IN CENTER OF INTERLOCK.

HARDWARE
(2) OPERATING HANDLE
(14) 5-POINT LOCKING SYSTEM
(16) MUSHROOM HEAD AND KEEPERS
(29) FLUSH BOLT
HINGE OPTIONS PER LEAF:
(6) OR (6A) RECTANGULAR DOOR 120' TALL: 6 INDIVIDUAL PAIRS OR (4) CLUSTERS OF 2 PAIRS.
ARCH TOP DOOR 120' TALL: 5 INDIVIDUAL PAIRS OR (4) CLUSTERS OF 2 PAIRS.
RECTANGULAR DOOR 96' TALL: 4 INDIVIDUAL PAIRS OR (3) CLUSTERS OF 2 PAIRS.
ARCH TOP DOOR 96' TALL: 4 INDIVIDUAL PAIRS OR (3) CLUSTERS OF 2 PAIRS.
GLAZING
SEE ALLOWABLE GLASS D.L.O. CHART ON PAGE 4

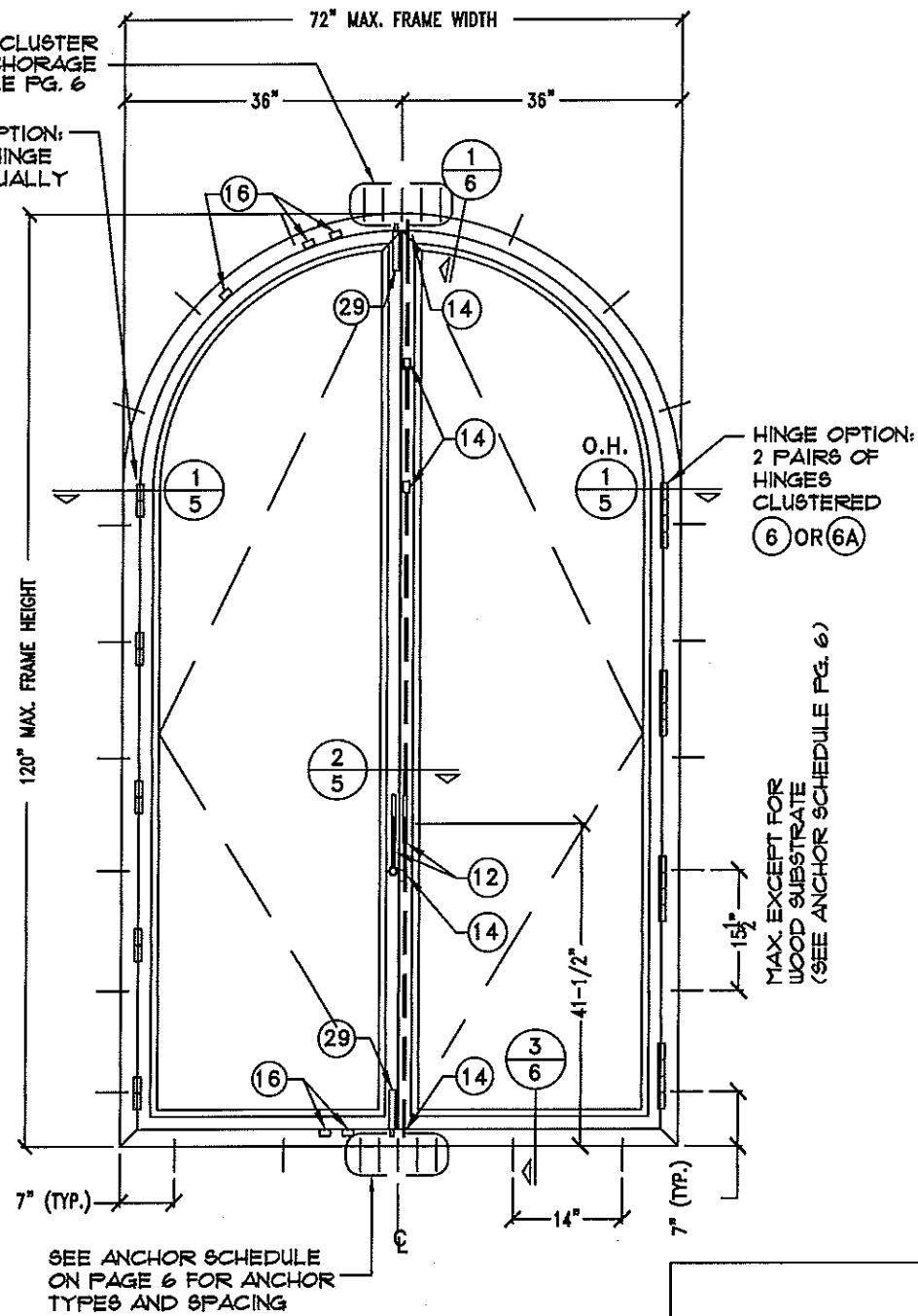

NOTE: FOR ODD NUMBER OF ANCHORS IN CLUSTER, INSTALL ONE ANCHOR IN CENTER OF INTERLOCK.

L.A. FINESTRA, L.C.
ITALIAN WINDOWS & DOORS
2790 Northwest 104th Court
Miami, FL 33172-2175
Phone (305) 599-8093
Fax (305) 592-4671

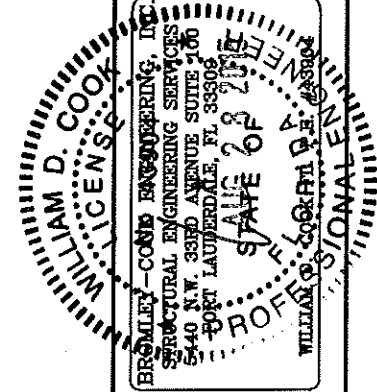

PRODUCT:
**EKU-53
IMPACT DOORS
HIGH LOAD**

REVISIONS			
No.	DATE	BY	DESCRIPTION

DATE: 10/16/2014
SCALE: N/A
DWG. BY: LA FIN
CHK. BY:

DRAWING No.:
FN-EKU53-FD
SHEET: 3 OF 15

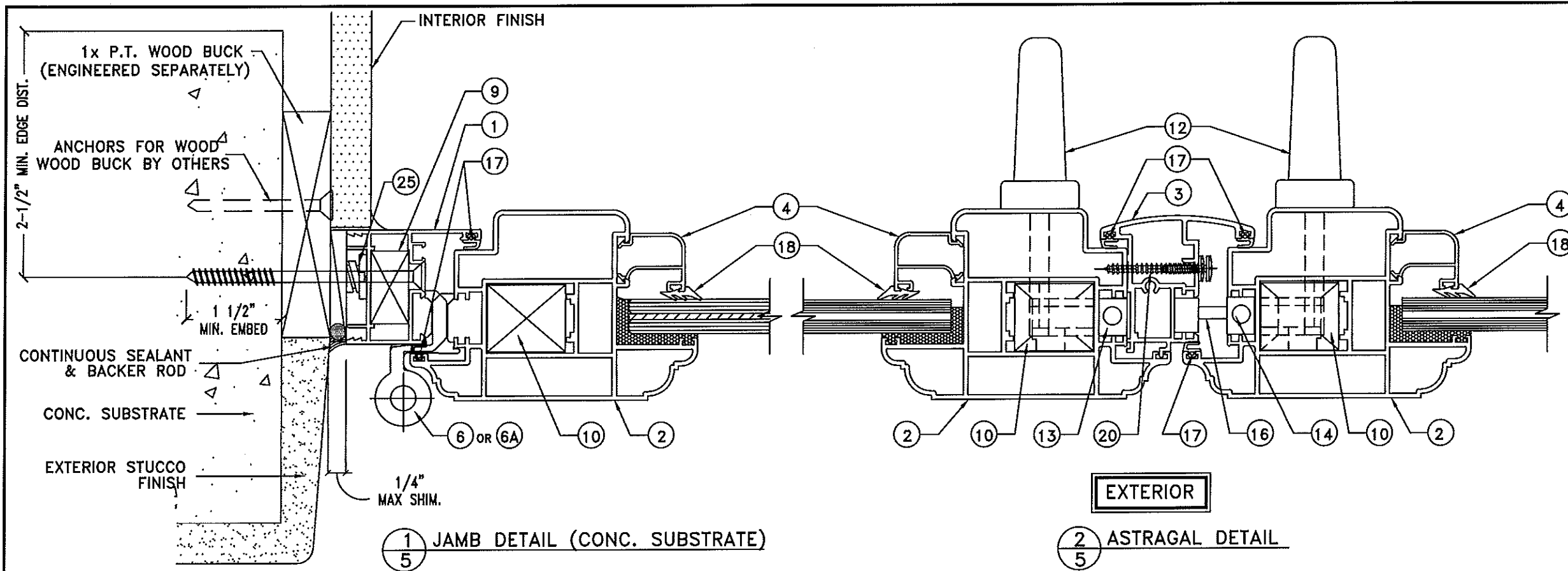

1 JAMB DETAIL (CONC. SUBSTRATE)
5

2 ASTRAGAL DETAIL
5

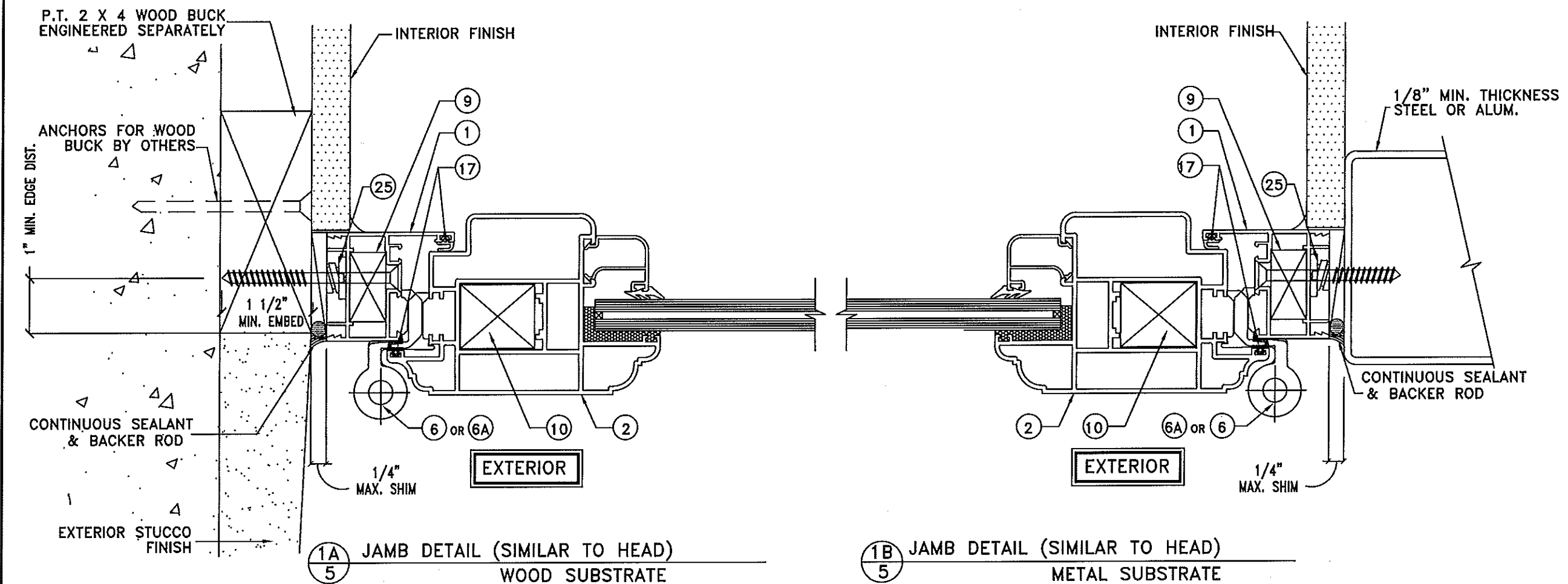

1A JAMB DETAIL (SIMILAR TO HEAD)
5 WOOD SUBSTRATE

1B JAMB DETAIL (SIMILAR TO HEAD)
5 METAL SUBSTRATE

LA FINESTRA, L.C.
 ITALIAN WINDOWS & DOORS
 2790 Northwest 104th Court
 Miami, FL 33172-2175
 Phone (305) 599-8093
 Fax (305) 592-4671

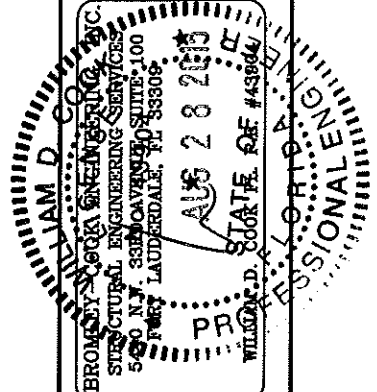

PRODUCT:
EKU-53
IMPACT DOORS
HIGH LOAD

REVISIONS	DATE	BY	DESCRIPTION
No.			

DATE: 10/16/2014
 SCALE: AS NOTED
 DWG. BY: LA FIN
 CHK. BY:

DRAWING No.:
 FN-EKU53-FD
 SHEET: 5 OF 15

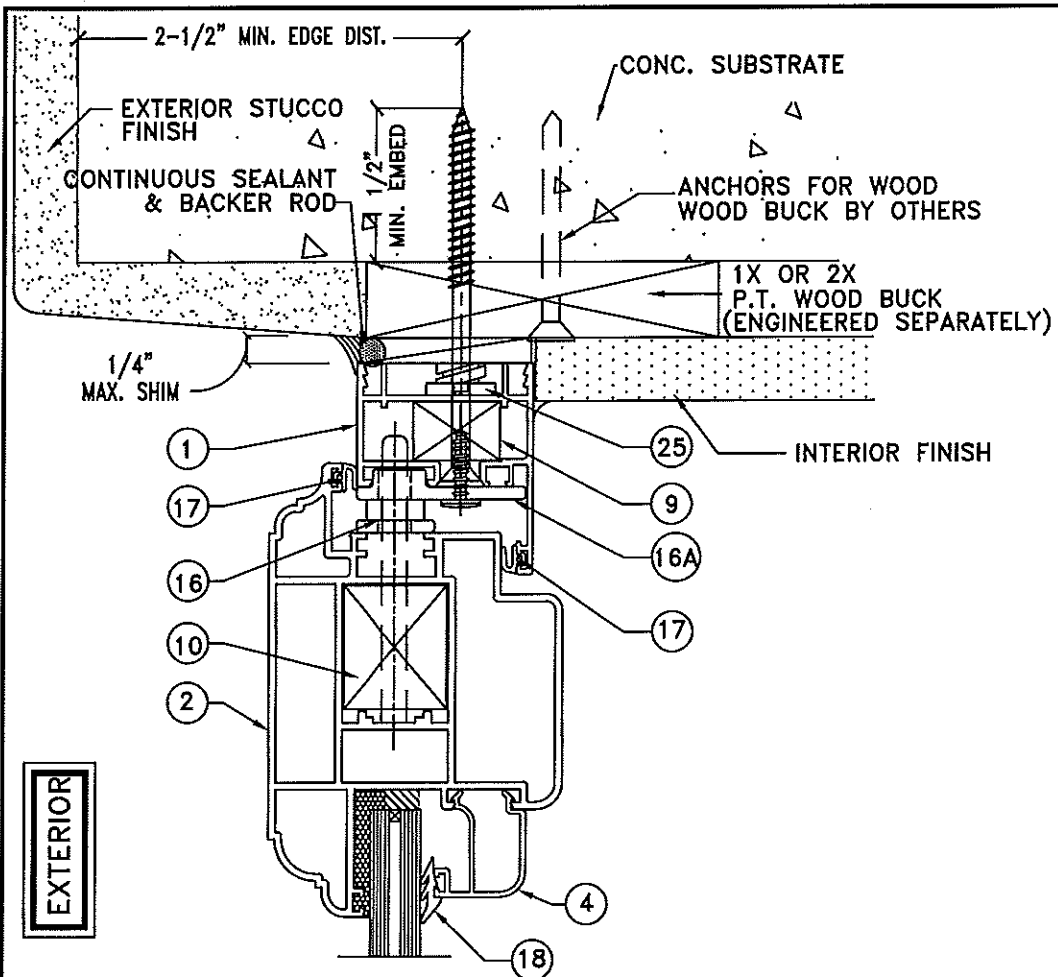

1 HEAD DETAIL (CONC. SUBSTRATE)
6

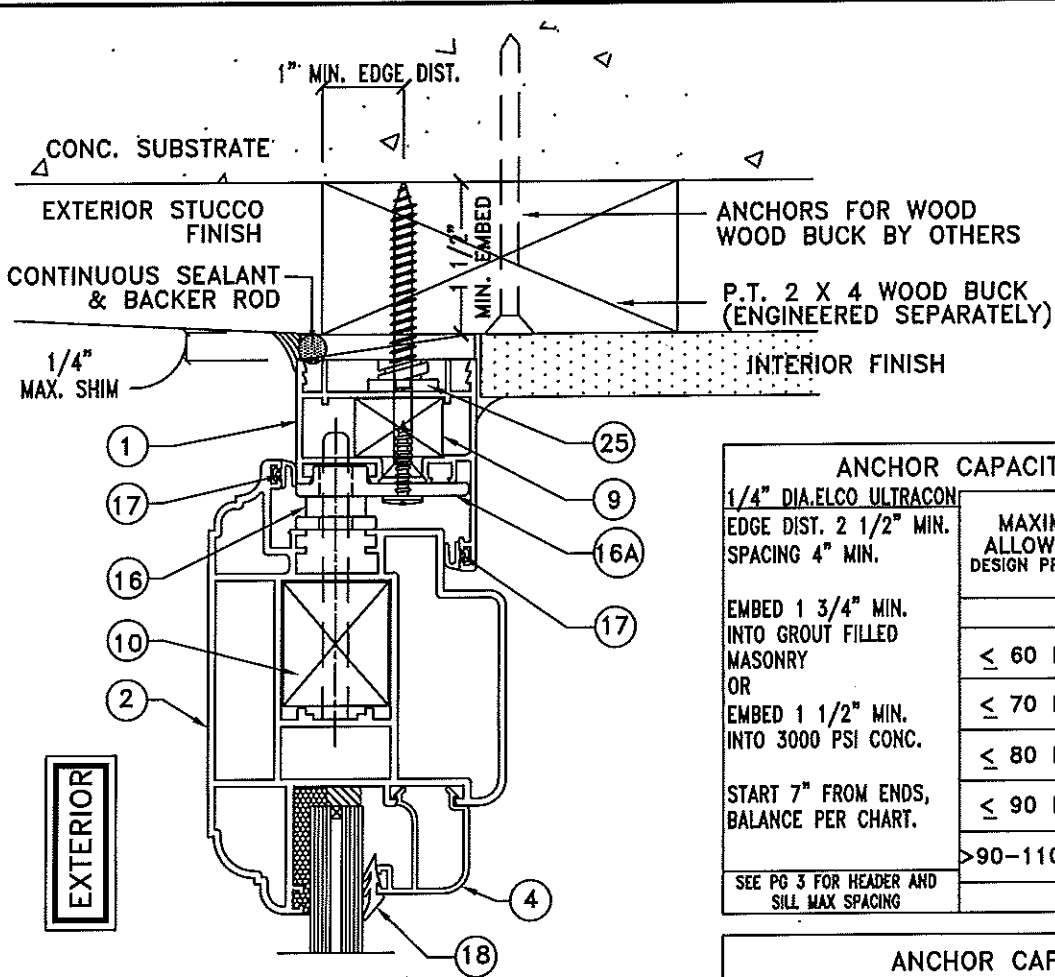

3 HEAD DETAIL (WOOD SUBSTRATE)
6

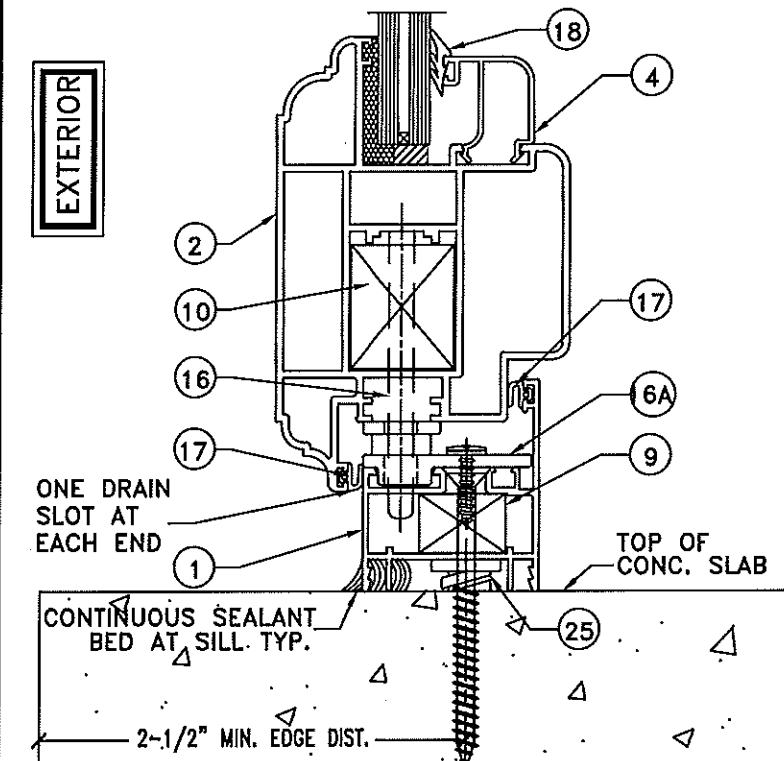

2 SILL DETAIL (STANDARD THRESHOLD)
6

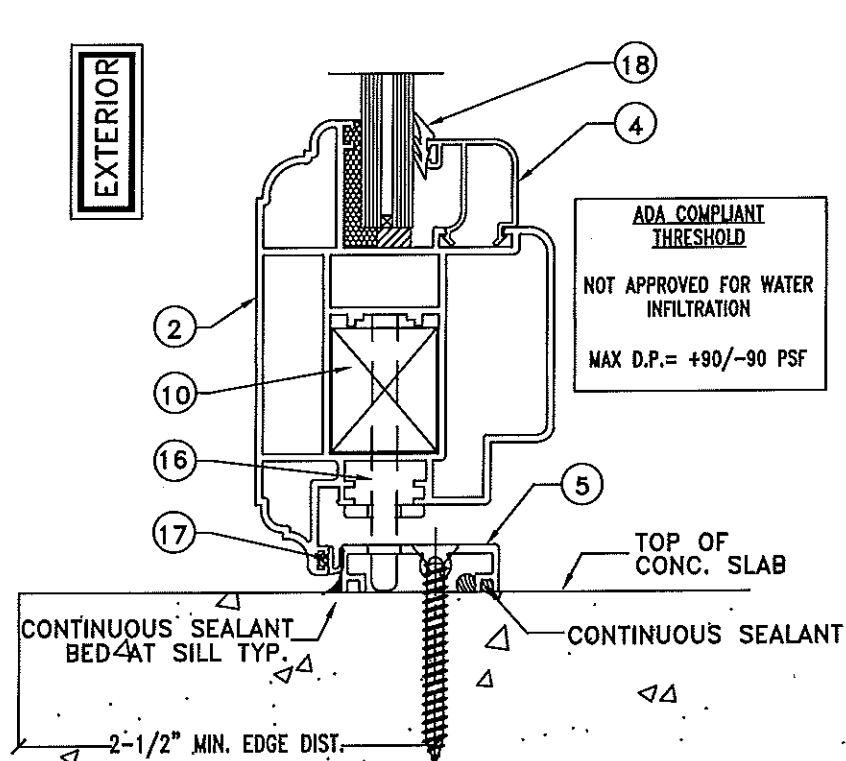

2 SILL DETAIL (ADA THRESHOLD)
6 SCALE: 1/4" = 1'-0"

ANCHOR CAPACITY CHART (CONCRETE SUBSTRATE)

1/4" DIA. ELCO ULTRACON
EDGE DIST. 2 1/2" MIN.
SPACING 4" MIN.

MAXIMUM ALLOWABLE DESIGN PRESSURE	ANCHORS AT JAMBS	QTY. ANCHORS AT HEAD OR SILL INTERLOCK	
		(W/ FRAME INSERT)	
		UP TO 96"	UP TO 120"
≤ 60 P.S.F.	15-1/2" C/C	2	3
≤ 70 P.S.F.	15-1/2" C/C	2	3
≤ 80 P.S.F.	15-1/2" C/C	3	3
≤ 90 P.S.F.	15-1/2" C/C	3	N/A
> 90-110 P.S.F.	15-1/2" C/C	3	N/A

EMBED 1 3/4" MIN. INTO GROUT FILLED MASONRY OR
EMBED 1 1/2" MIN. INTO 3000 PSI CONC.

START 7" FROM ENDS, BALANCE PER CHART.

SEE PG 3 FOR HEADER AND SILL MAX SPACING

SPACED 4" APART

ANCHOR CAPACITY CHART (STEEL SUBSTRATE)

#14 P.H.S.M.S. OR
#14 SELF DRILLING

MAXIMUM ALLOWABLE DESIGN PRESSURE	ANCHORS AT JAMBS	QTY. ANCHORS AT HEAD OR SILL INTERLOCK	
		(W/ FRAME INSERT)	
		UP TO 96"	UP TO 120"
≤ 60 P.S.F.	15-1/2" C/C	2	3
≤ 70 P.S.F.	15-1/2" C/C	2	3
≤ 80 P.S.F.	15-1/2" C/C	3	3
≤ 90 P.S.F.	15-1/2" C/C	3	N/A
> 90-110 P.S.F.	15-1/2" C/C	3	N/A

INTO 1/8" THK. ASTM A36

START 7" FROM ENDS, BALANCE PER CHART.

SEE PG 3 FOR HEADER AND SILL MAX SPACING

SPACED 2 1/2" APART

ANCHOR CAPACITY CHART (WOOD SUBSTRATE)

#14 P.H.S.M.S. OR
#14 WOOD SCREW

MAXIMUM ALLOWABLE DESIGN PRESSURE	ANCHORS AT JAMBS	QTY. ANCHORS AT HEAD OR SILL INTERLOCK	
		(W/ FRAME INSERT)	
		UP TO 96"	UP TO 120"
≤ 60 P.S.F.	12" C/C	4	5
≤ 70 P.S.F.	12" C/C	4	5
≤ 80 P.S.F.	12" C/C	5	6
≤ 90 P.S.F.	12" C/C	5	N/A
> 90-110 P.S.F.	12" C/C	6	N/A

EMBED 1 1/2" MIN. INTO NO. 2 SYP.

START 7" FROM ENDS, BALANCE PER CHART.

SEE PG 3 FOR HEADER AND SILL MAX SPACING

SPACED 2 1/2" APART

LA FINESTRA, L.C.
ITALIAN WINDOWS & DOORS
2790 Northwest 104th Court
Miami, FL 33172-2175
Phone (305) 599-8093
Fax (305) 592-4671

PROFESSIONAL ENGINEER
BRIAN J. COUGHLIN, INC.
STRUCTURAL ENGINEERING SERVICES
5440 N.W. 68th AVENUE, SUITE 200
FORT LAUDERDALE, FL 33308
P.E. #43964

PRODUCT:
EKU-53
IMPACT DOORS
HIGH LOAD

NO.	DATE	BY	DESCRIPTION

DATE: 10/16/2014
SCALE: 1/4" = 1'-0"
DWG. BY: LA FIN
CHK. BY:

DRAWING No.: FN-EKU53-FD
SHEET: 6 OF 15

PROFILE COMBINATIONS

NOTE: PLEASE SEE
D.P. LIMITATIONS FOR
GLAZING ON SHEET 4

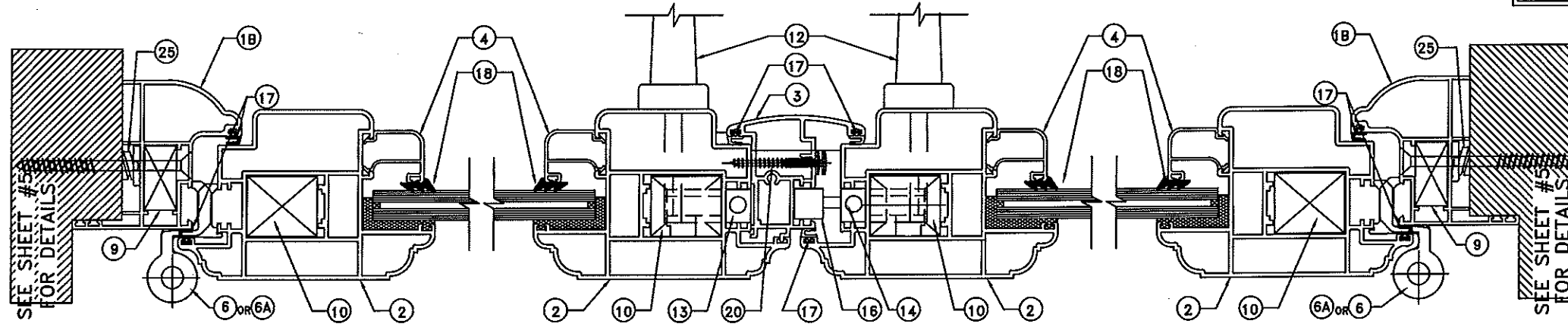

COMBINATION 1

MAXIMUM P.S.F. @ 96" +110.00 -110.00 DESIGN PRESSURE - WATER INFILTRATION TEST PRESSURE = 13.5 PSF
 MAXIMUM P.S.F. @ 120" +80.00 -80.00 DESIGN PRESSURE - WATER INFILTRATION TEST PRESSURE = 12.0 PSF

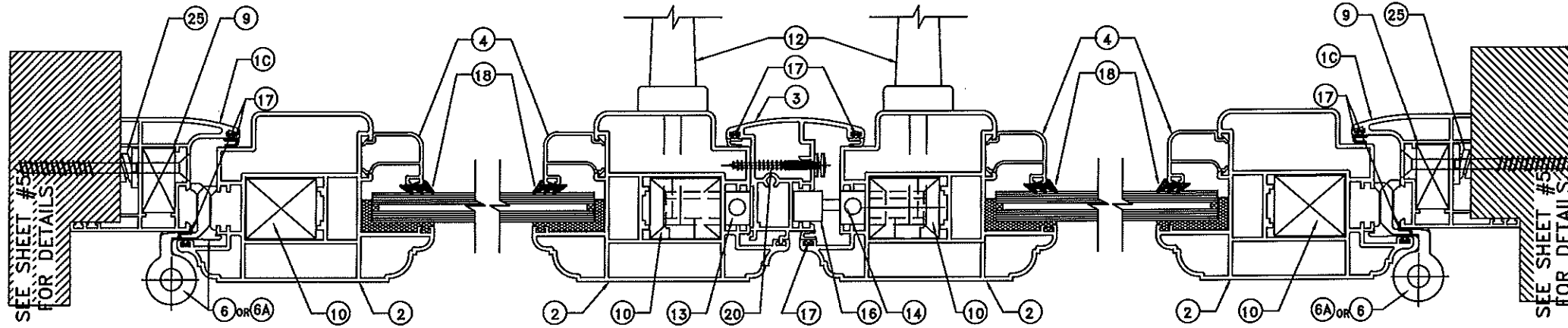

COMBINATION 2

MAXIMUM P.S.F. @ 96" +110.00 -110.00 DESIGN PRESSURE - WATER INFILTRATION TEST PRESSURE = 13.5 PSF
 MAXIMUM P.S.F. @ 120" +80.00 -80.00 DESIGN PRESSURE - WATER INFILTRATION TEST PRESSURE = 12.0 PSF

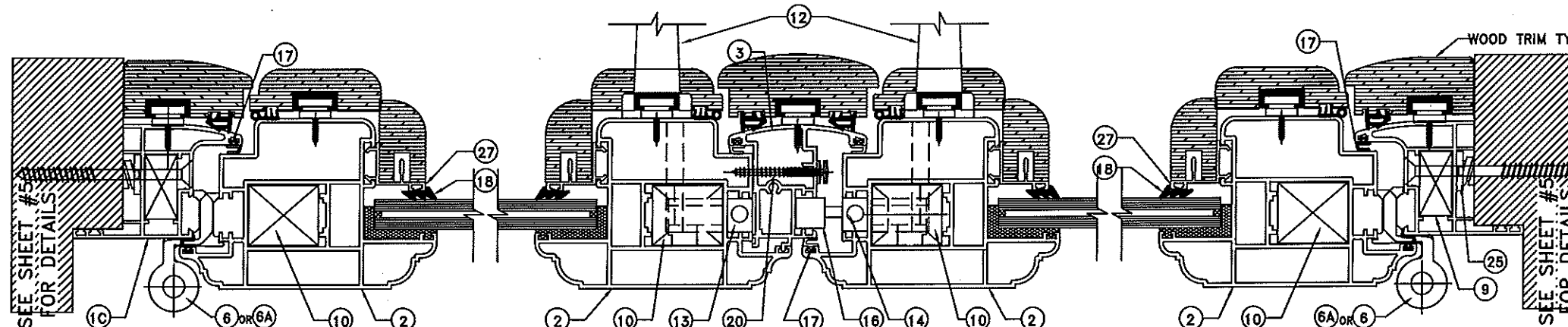

COMBINATION 2 WITH WOOD TRIM

MAXIMUM P.S.F. @ 120" +80.00 -80.00 DESIGN PRESSURE - WATER INFILTRATION TEST PRESSURE = 12.0 PSF

LA FINESTRA, L.C.
 ITALIAN WINDOWS & DOORS
 2790 Northwest 104th Court
 Miami, FL 33172-2175
 Phone (305) 599-8093
 Fax (305) 592-4671

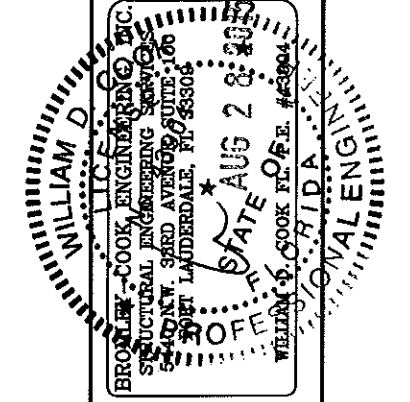

BROOKLYN-COOK ENGINEERING, INC.
 STRUCTURAL ENGINEERING SERVICES
 5740 NEW 34RD AVENUE SUITE 106
 FORT LAUDERDALE, FL 33306
 STATE OF FLORIDA LICENSE #45394

PRODUCT:
EKU-53
IMPACT DOORS
HIGH LOAD

REVISIONS	NO.	DATE	BY	DESCRIPTION

DATE: 10/16/2014
 SCALE: AS NOTED
 DWG. BY: LA FIN
 CHK. BY:

DRAWING No.:
FN-EKU53-FD
 SHEET: 7 OF 15

PROFILE COMBINATIONS

NOTE: PLEASE SEE D.P. LIMITATIONS FOR GLAZING ON SHEET 4

LA FINESTRA, L.C.
 ITALIAN WINDOWS & DOORS
 2790 Northwest 104th Court
 Miami, FL 33172-2175
 Phone (305) 599-8093
 Fax (305) 592-4671

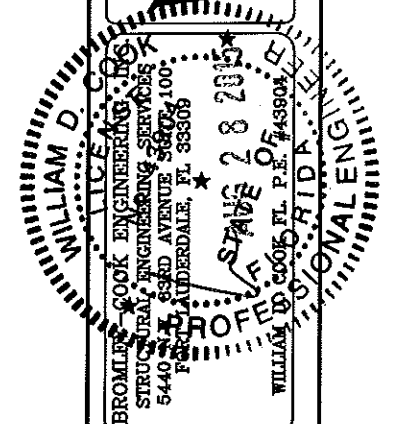
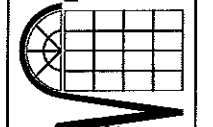

PRODUCT:
 EKU-53
 IMPACT DOORS
 HIGH LOAD

REVISIONS	No.	DATE	BY	DESCRIPTION

DATE: 10/16/2014
 SCALE: AS NOTED
 DWG. BY: LA FIN
 CHK. BY:

DRAWING No.:
 FN-EKU53-FD
 SHEET: 8 OF 15

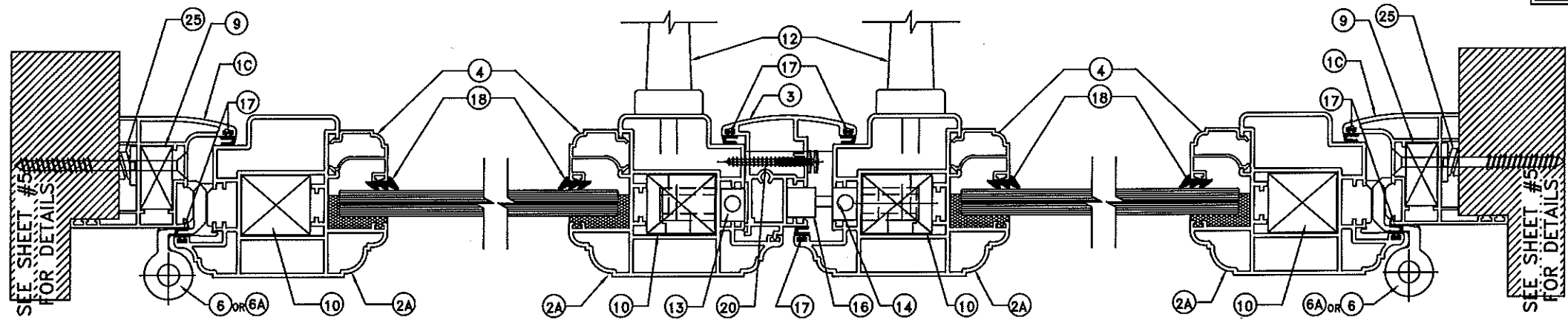

COMBINATION 3

MAXIMUM P.S.F. @ 96" +110.00 -110.00 DESIGN PRESSURE - WATER INFILTRATION TEST PRESSURE = 13.5 PSF
 MAXIMUM P.S.F. @ 120" +80.00 -80.00 DESIGN PRESSURE - WATER INFILTRATION TEST PRESSURE = 12.0 PSF

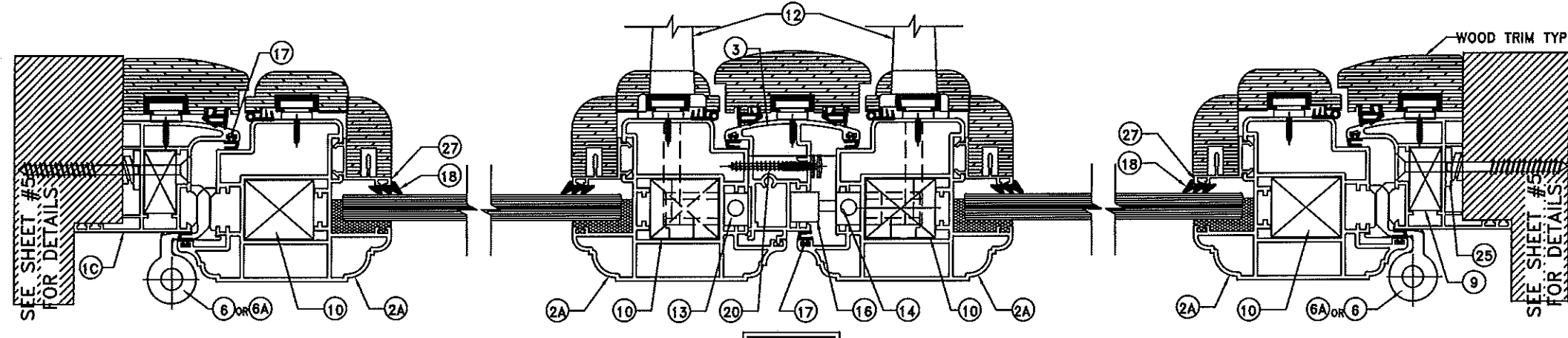

COMBINATION 3 WITH WOOD TRIM

MAXIMUM P.S.F. @ 120" +80.00 -80.00 DESIGN PRESSURE - WATER INFILTRATION TEST PRESSURE = 12.0 PSF

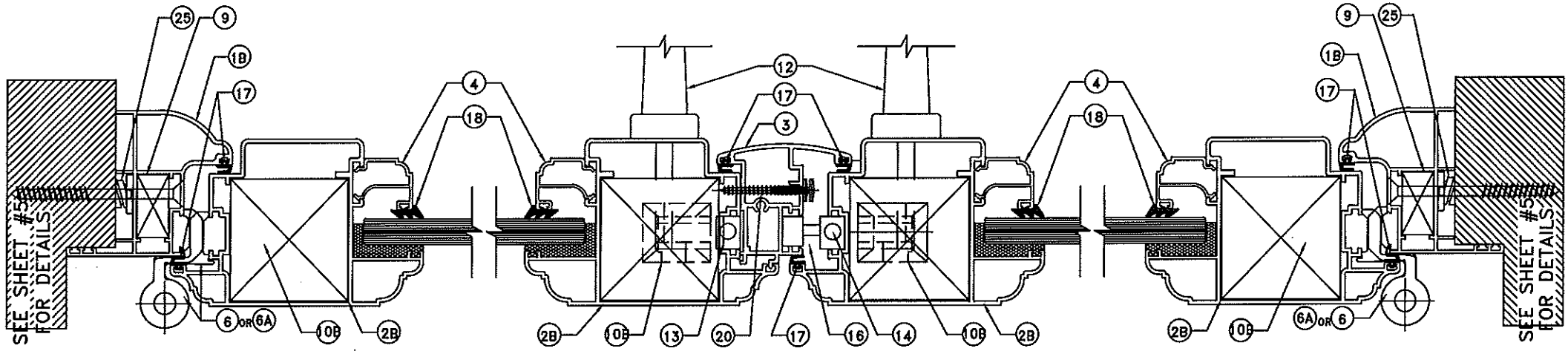

COMBINATION 4

MAXIMUM P.S.F. @ 96" +110.00 -110.00 DESIGN PRESSURE - WATER INFILTRATION TEST PRESSURE = 13.5 PSF
 MAXIMUM P.S.F. @ 120" +80.00 -80.00 DESIGN PRESSURE - WATER INFILTRATION TEST PRESSURE = 12.0 PSF

PROFILE COMBINATIONS

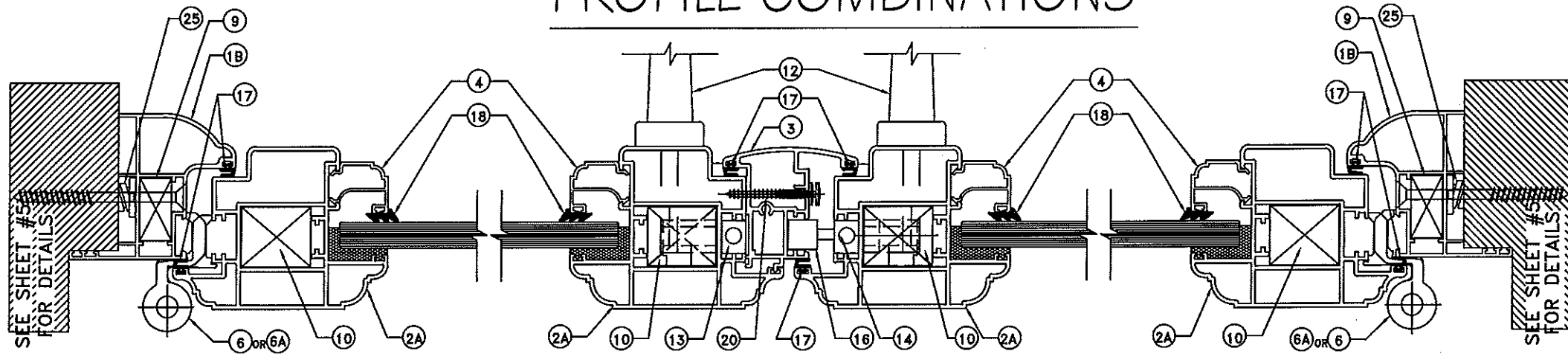

COMBINATION 5

EXTERIOR

MAXIMUM P.S.F. @ 96" +110.00 -110.00 DESIGN PRESSURE - WATER INFILTRATION TEST PRESSURE = 13.5 PSF
 MAXIMUM P.S.F. @ 120" +80.00 -80.00 DESIGN PRESSURE - WATER INFILTRATION TEST PRESSURE = 12.0 PSF

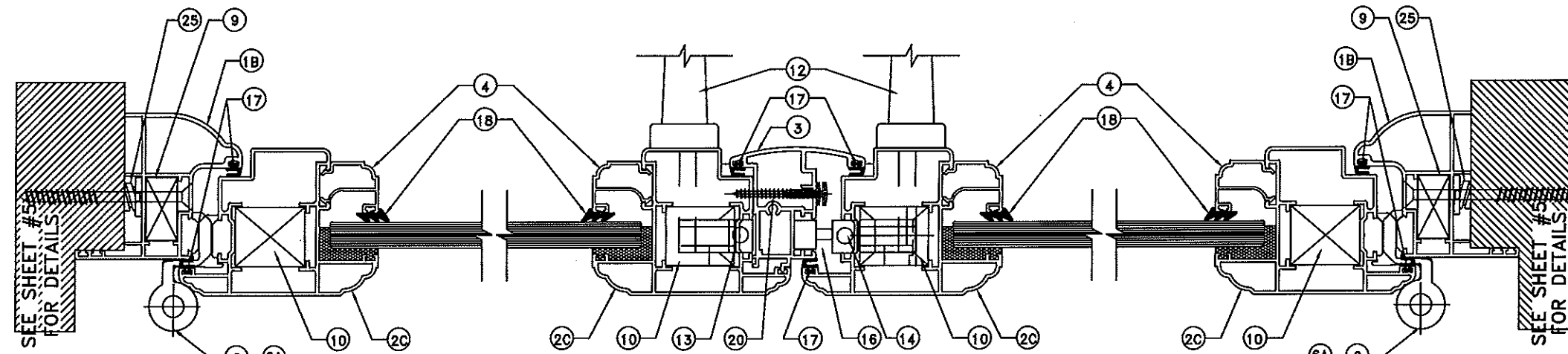

COMBINATION 6

EXTERIOR

MAXIMUM OF 96" H D.P. = +80 / -80 PSF WATER @ 12.0 PSF

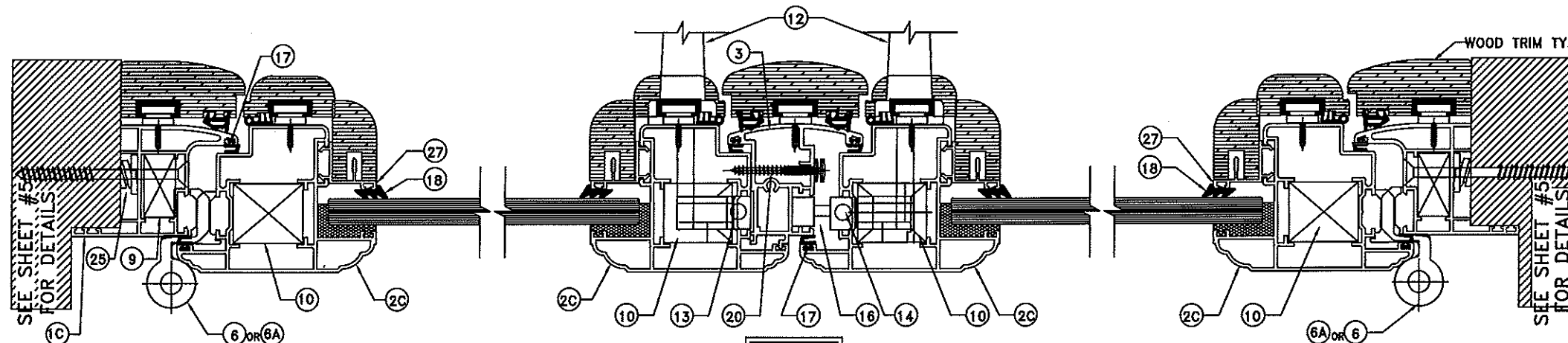

COMBINATION 7 WITH WOOD TRIM

EXTERIOR

MAXIMUM OF 96" H D.P. = +80 / -80 PSF WATER @ 12.0 PSF

NOTE: WOOD TRIM IS OPTIONAL

NOTE: PLEASE SEE D.P. LIMITATIONS FOR GLAZING ON SHEET 4

LA FINESTRA, L.C.
 ITALIAN WINDOWS & DOORS
 2790 Northwest 104th Court
 Miami, FL 33172-2175
 Phone (305) 589-8093
 Fax (305) 592-4671

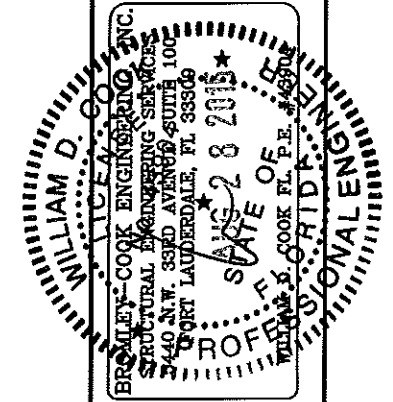

WILLIAM D. COOK, P.E.
 BRADLEY-COOK ENGINEERING, INC.
 STRUCTURAL ENGINEERING SERVICES
 7440 N.W. 33RD AVENUE, SUITE 100
 FORT LAUDERDALE, FL 33306
 DATE: 2/8/2015

PRODUCT:
 EKU-53
 IMPACT DOORS
 HIGH LOAD

REVISIONS	DATE	BY	DESCRIPTION
No.			

DATE: 10/16/2014
 SCALE: AS NOTED
 DWG. BY: LA FIN
 CHK. BY:

DRAWING No.:
 FN-EKU53-FD
 SHEET: 9 OF 15

PROFILE COMBINATIONS

NOTE: PLEASE SEE D.P. LIMITATIONS FOR GLAZING ON SHEET 4

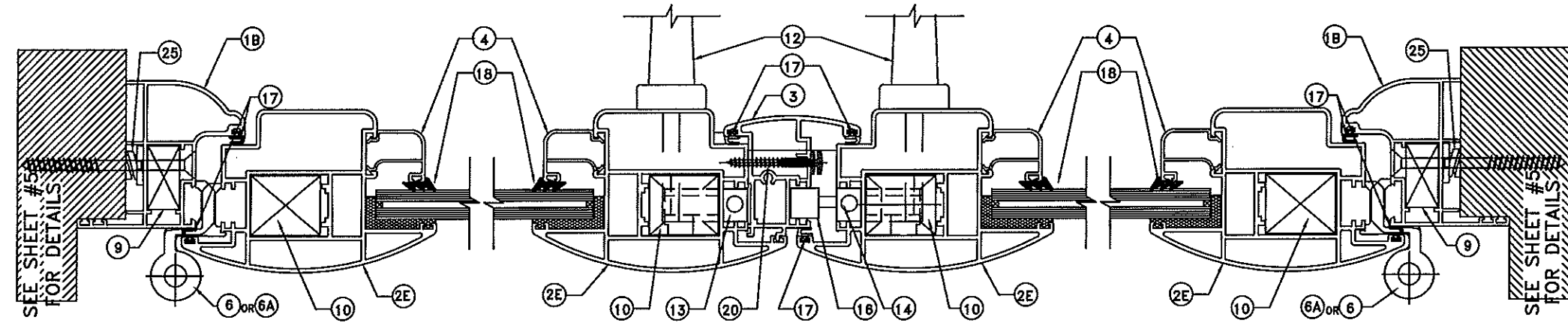

○ COMBINATION 8 (ALTERNATE EXTRUSION)

MAXIMUM P.S.F. @ 96" +110.00 -110.00 DESIGN PRESSURE - WATER INFILTRATION TEST PRESSURE = 13.5 PSF
 MAXIMUM P.S.F. @ 120" +80.00 -80.00 DESIGN PRESSURE - WATER INFILTRATION TEST PRESSURE = 12.0 PSF

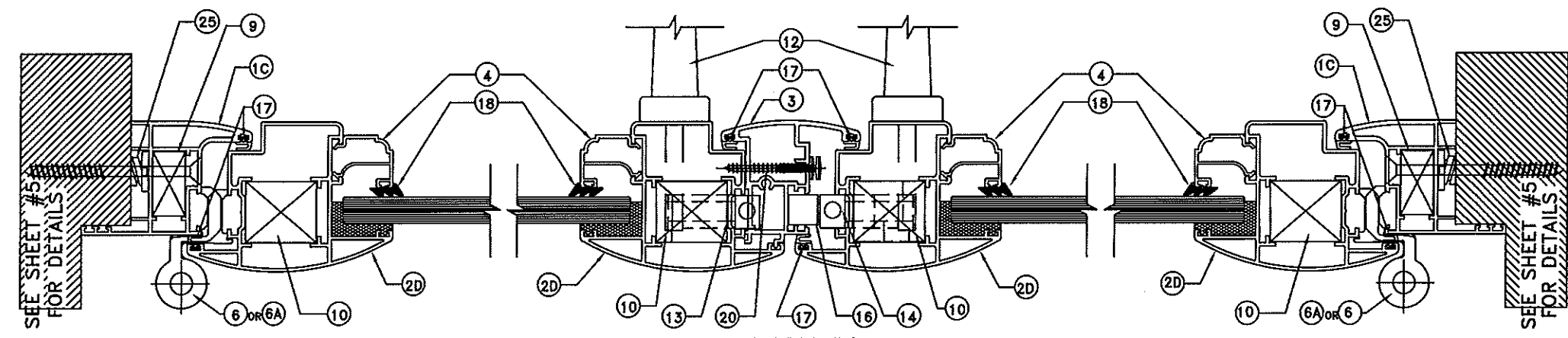

○ COMBINATION 10 (ALTERNATE EXTRUSION)

MAXIMUM P.S.F. @ 96" +80 -80 DESIGN PRESSURE - WATER INFILTRATION TEST PRESSURE = 12 PSF

LA FINESTRA, L.C.
 ITALIAN WINDOWS & DOORS
 2790 Northwest 104th Court
 Miami, FL 33172-2175
 Phone (305) 599-8093
 Fax (305) 592-4671

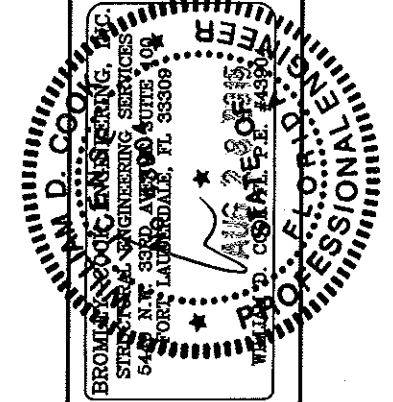
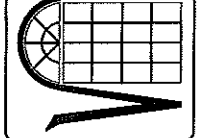

PRODUCT:
 EKU-53
 IMPACT DOORS
 HIGH LOAD

REVISIONS	
No.	DESCRIPTION

DATE: 10/16/2014
 SCALE: AS NOTED
 DWG. BY: LA FIN
 CHK. BY:

DRAWING No.:
 FN-EKU53-FD
 SHEET: 10 OF 15

PROFILE COMBINATIONS

NOTE: PLEASE SEE D.P. LIMITATIONS FOR GLAZING ON SHEET 4

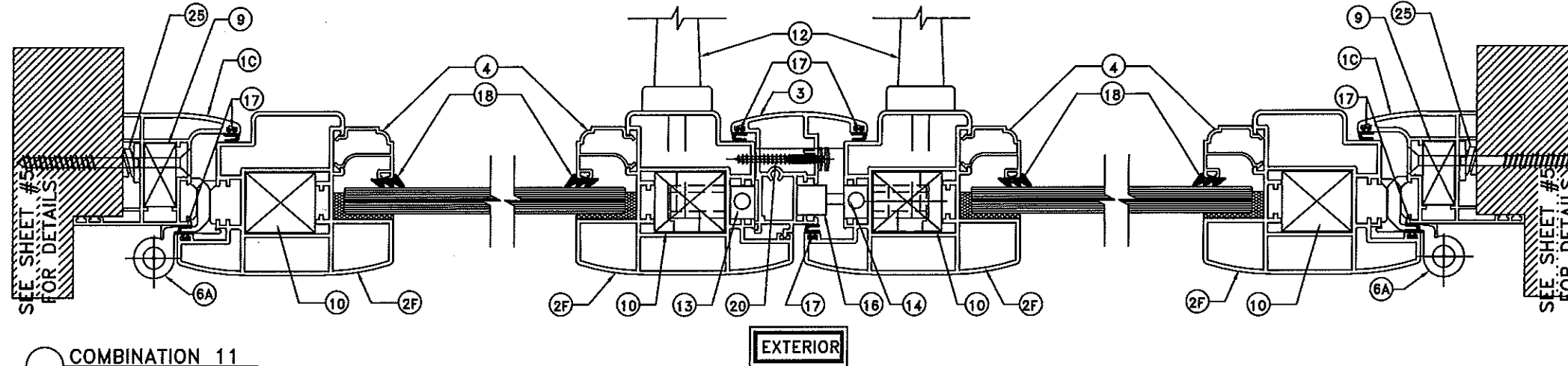

COMBINATION 11

MAXIMUM P.S.F. ● 96" +110.00 -110.00 DESIGN PRESSURE - WATER INFILTRATION TEST PRESSURE = 13.5 PSF
 MAXIMUM P.S.F. ● 120" +80.00 -80.00 DESIGN PRESSURE - WATER INFILTRATION TEST PRESSURE = 12.0 PSF

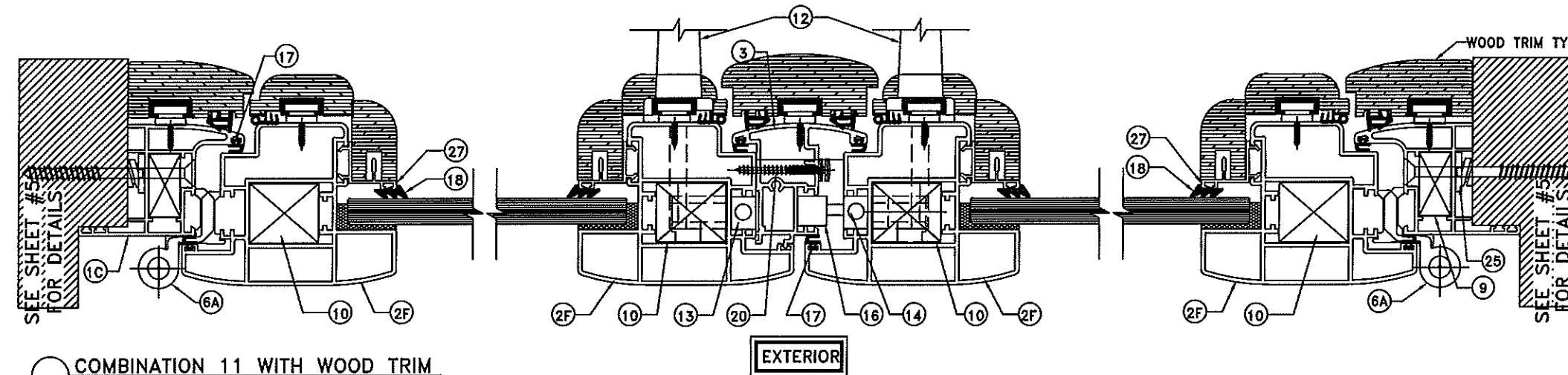

COMBINATION 11 WITH WOOD TRIM

MAXIMUM P.S.F. ● 120" +80.00 -80.00 DESIGN PRESSURE - WATER INFILTRATION TEST PRESSURE = 12.0 PSF

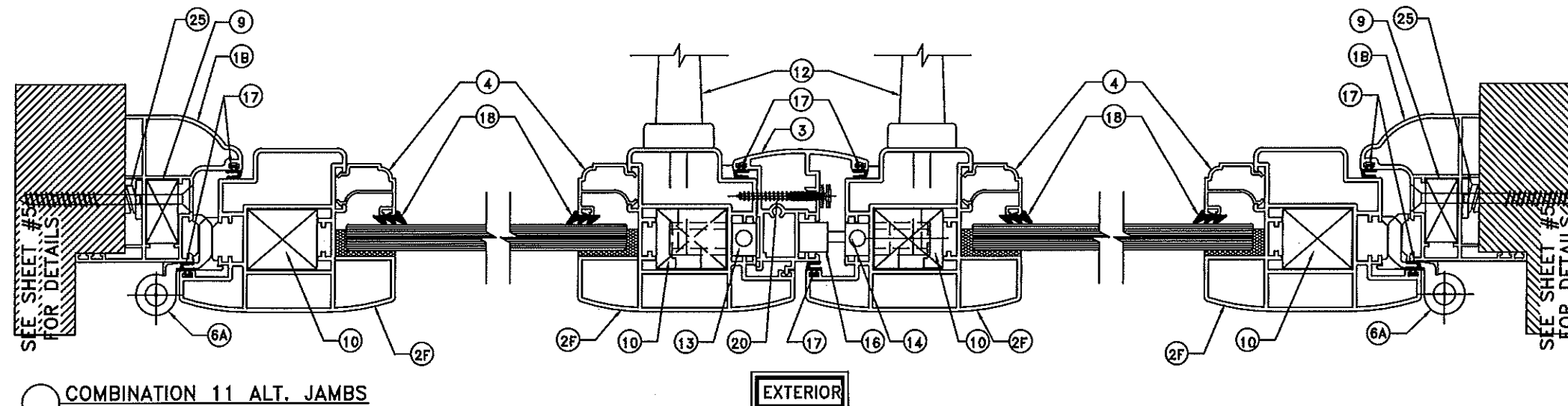

COMBINATION 11 ALT. JAMBS

MAXIMUM P.S.F. ● 96" +110.00 -110.00 DESIGN PRESSURE - WATER INFILTRATION TEST PRESSURE = 13.5 PSF
 MAXIMUM P.S.F. ● 120" +80.00 -80.00 DESIGN PRESSURE - WATER INFILTRATION TEST PRESSURE = 12.0 PSF

LA FINESTRA, L.C.
 ITALIAN WINDOWS & DOORS
 2790 Northwest 104th Court
 Miami, FL 33172-2175
 Phone (305) 599-8093
 Fax (305) 592-4671

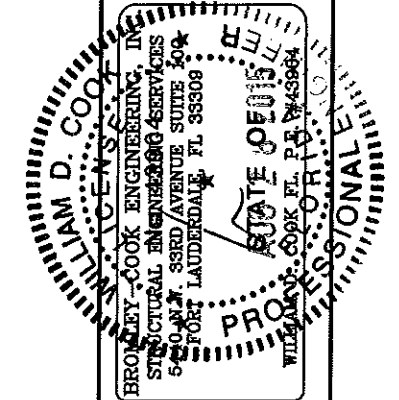

PRODUCT:
 EKU-53
 IMPACT DOORS
 HIGH LOAD

REVISIONS	No.	DATE	BY	DESCRIPTION

DATE: 10/16/2014
 SCALE: AS NOTED
 DWG. BY: LA FIN
 CHK. BY:

DRAWING No.:
 FN-EKU53-FD
 SHEET: 11 OF 15

PROFILE COMBINATIONS

NOTE: PLEASE SEE D.P. LIMITATIONS FOR GLAZING ON SHEET 4

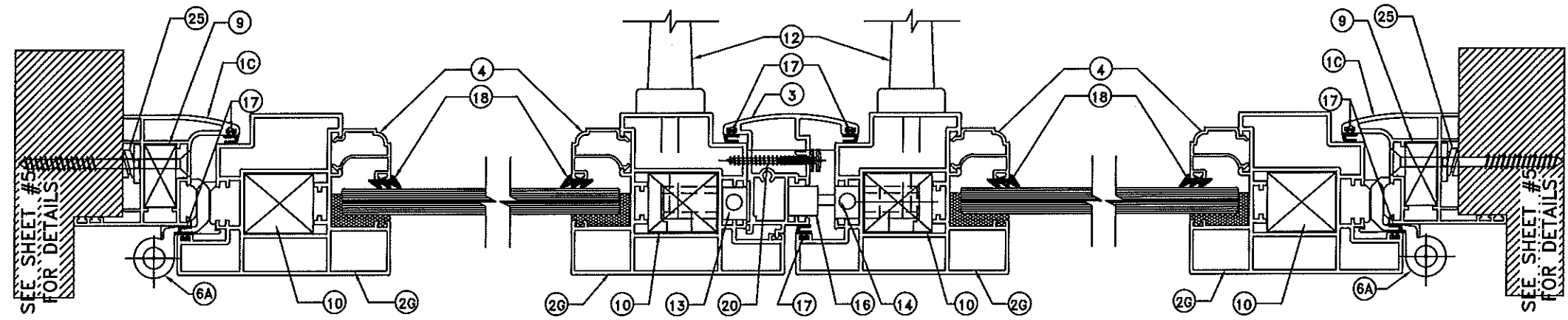

COMBINATION 12

MAXIMUM P.S.F. @ 96" +110.00 -110.00 DESIGN PRESSURE - WATER INFILTRATION TEST PRESSURE = 13.5 PSF
 MAXIMUM P.S.F. @ 120" +80.00 -80.00 DESIGN PRESSURE - WATER INFILTRATION TEST PRESSURE = 12.0 PSF

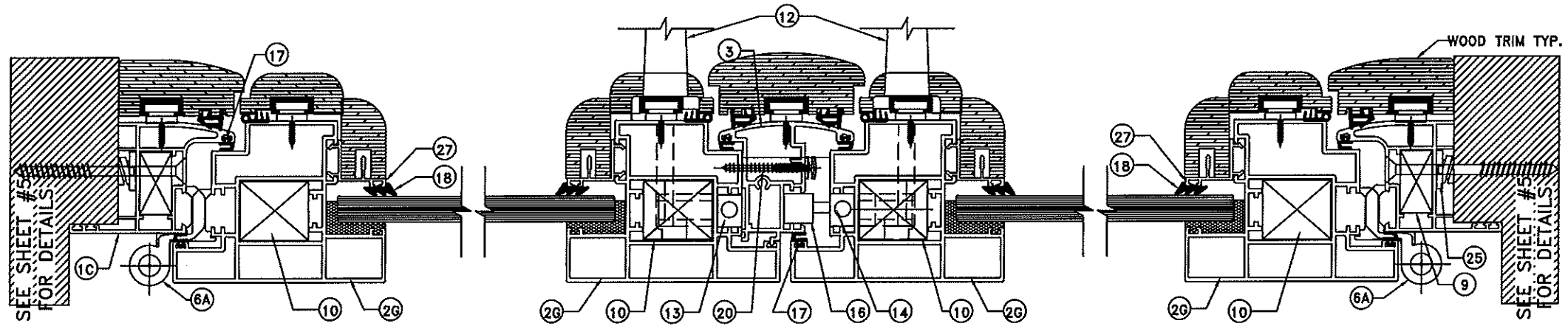

COMBINATION 12 WITH WOOD TRIM

MAXIMUM P.S.F. @ 120" +80.00 -80.00 DESIGN PRESSURE - WATER INFILTRATION TEST PRESSURE = 12.0 PSF

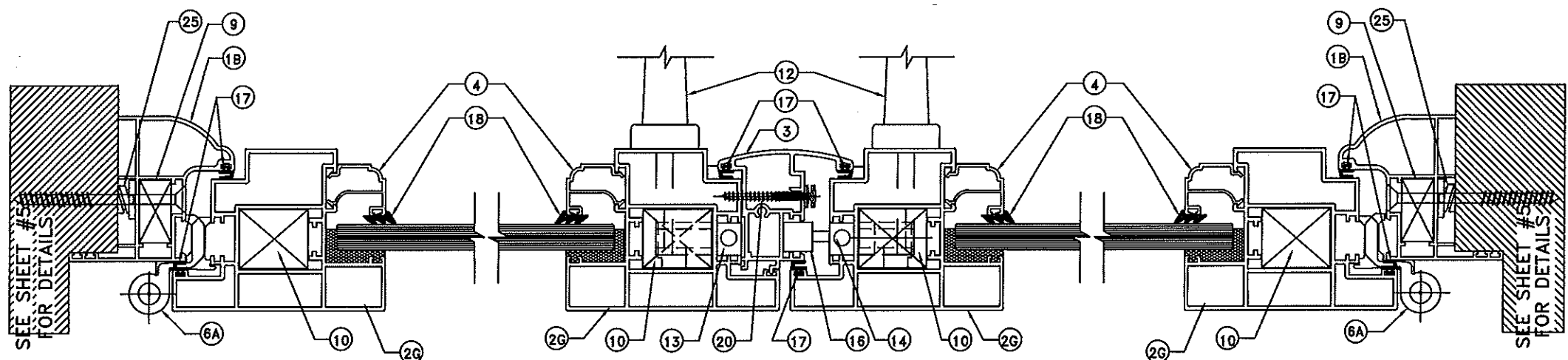

COMBINATION 12 ALT. FRAME

MAXIMUM P.S.F. @ 96" +110.00 -110.00 DESIGN PRESSURE - WATER INFILTRATION TEST PRESSURE = 13.5 PSF
 MAXIMUM P.S.F. @ 120" +80.00 -80.00 DESIGN PRESSURE - WATER INFILTRATION TEST PRESSURE = 12.0 PSF

LA FINESTRA, L.C.
 ITALIAN WINDOWS & DOORS
 2790 Northwest 104th Court
 Miami, FL 33172-2175
 Phone (305) 599-8093
 Fax (305) 592-4671

WILLIAM D. COOK ENGINEERING, INC.
 STRUCTURAL ENGINEERING SERVICES
 9446 N.W. 33RD AVENUE SUITE 100
 FORT LAUDERDALE, FL 33309
 AUG 28 2015
 STATE OF FLORIDA
 WILLIAM D. COOK FL. P.E. #33604

PRODUCT:
 EKU-53
 IMPACT DOORS
 HIGH LOAD

REVISIONS	No.	DATE	BY	DESCRIPTION

DATE: 10/16/2014
 SCALE: AS NOTED
 DWG. BY: LA FIN
 CHK. BY:

DRAWING No.:
 FN-EKU53-FD
 SHEET: 12 OF 15

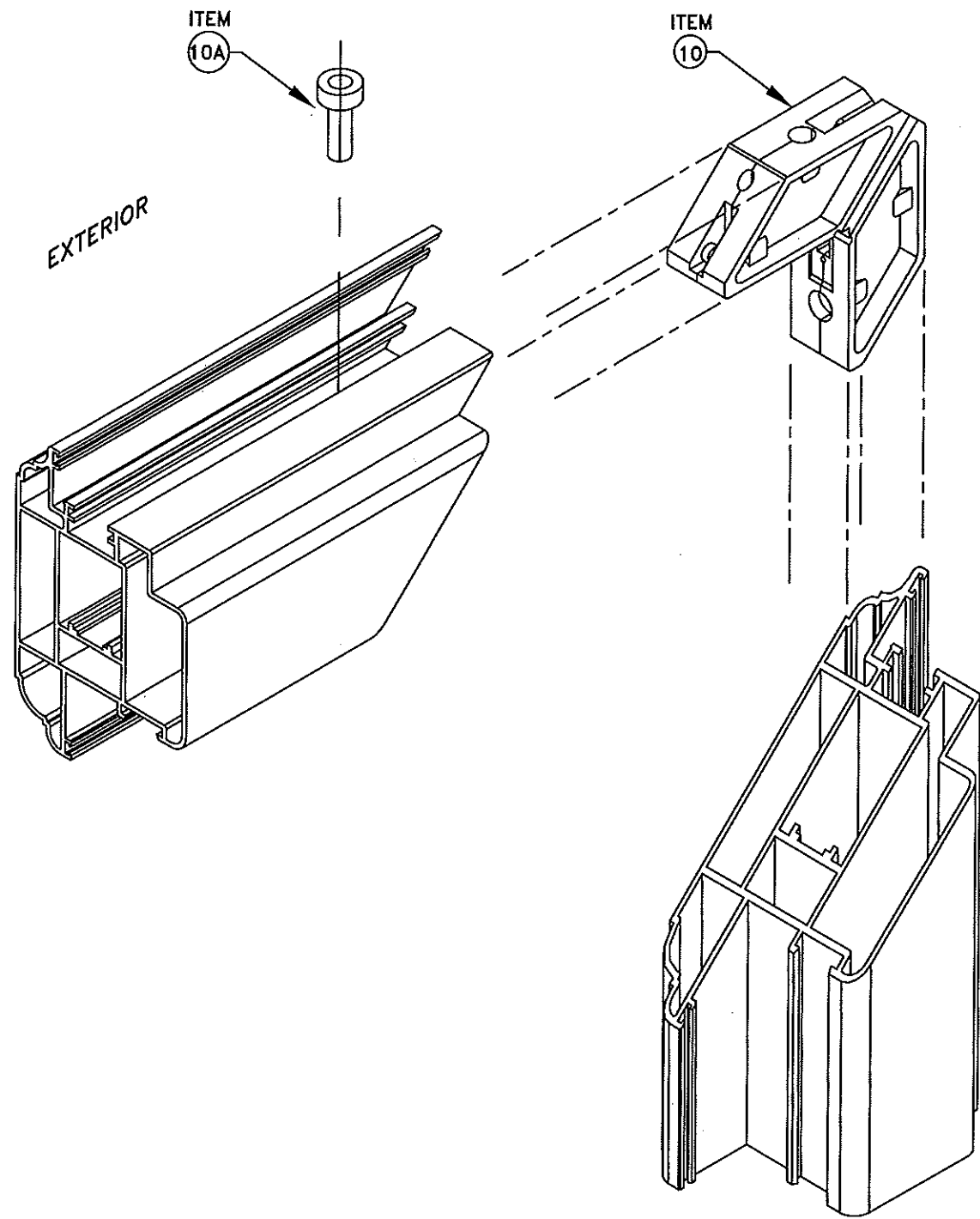

DOOR PANEL CORNER DETAIL

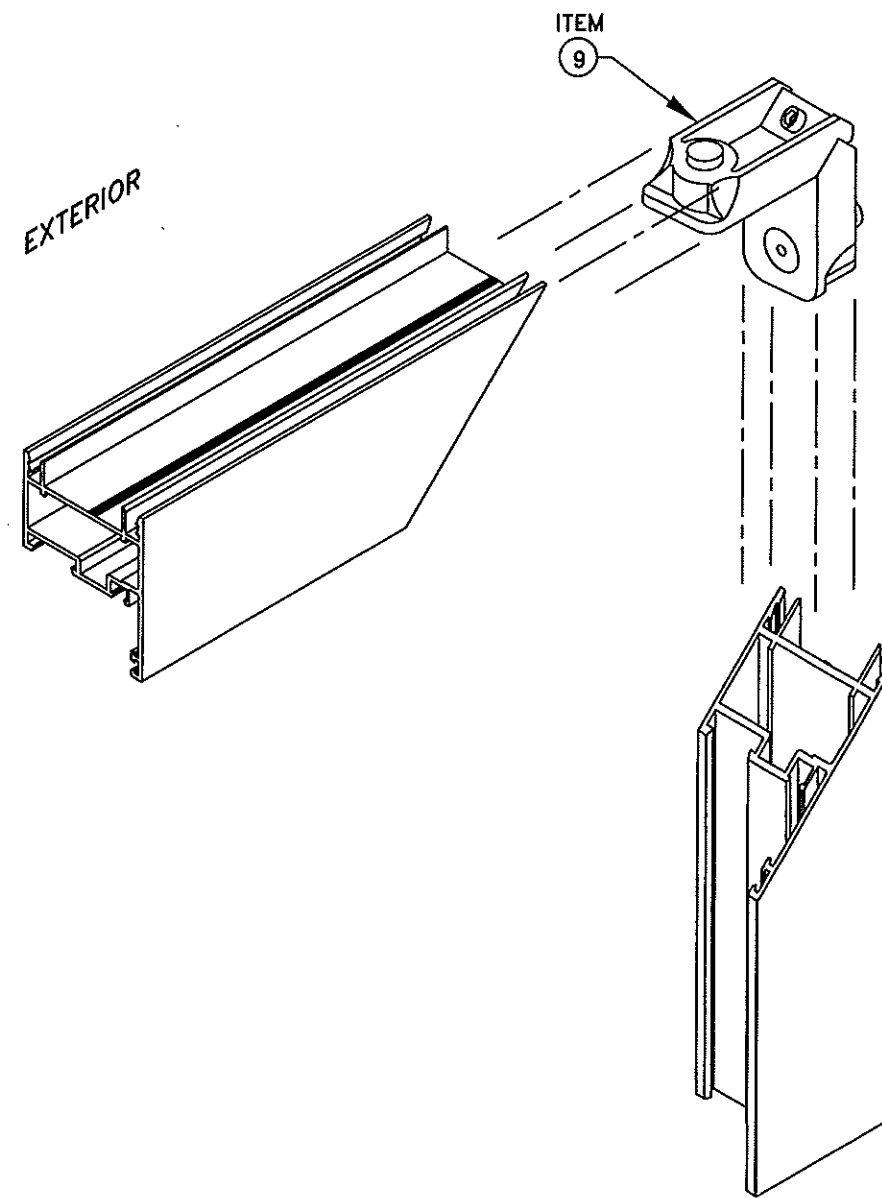

DOOR FRAME CORNER DETAIL

NOTE: SEAL JOINTS WITH
POLYURETHANE SEALANT
DURING ASSEMBLY

LA FINESTRA, L.C.
ITALIAN WINDOWS & DOORS
2790 Northwest 104th Court
Miami, FL 33172-2175
Phone (305) 599-8093
Fax (305) 592-4671

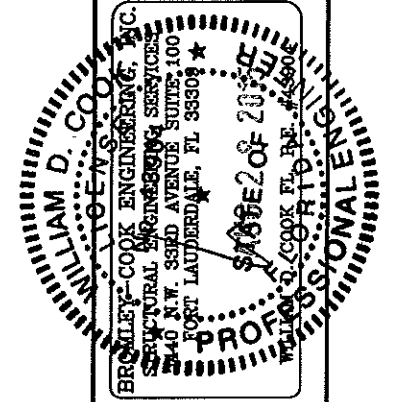
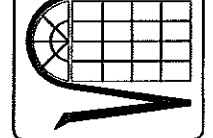

PRODUCT:
**EKU-53
IMPACT DOORS
HIGH LOAD**

REVISIONS	
No.	DESCRIPTION

DATE: 10/16/2014
SCALE: AS NOTED
DWG. BY: LA FIN
CHK. BY:

DRAWING No.:
FN-EKU53-FD

SHEET: 13 OF 15

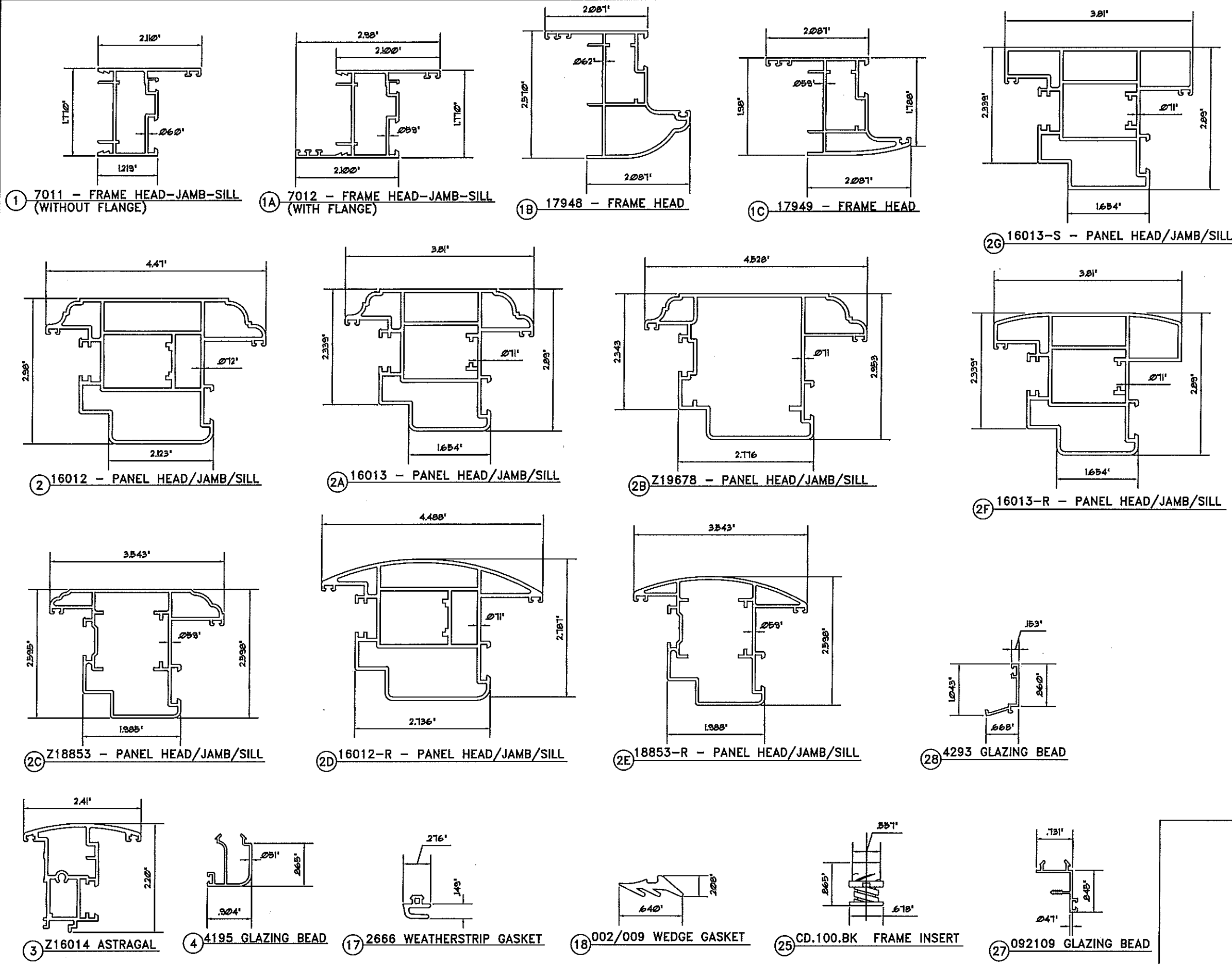

LA FINESTRA, L.C.
 ITALIAN WINDOWS & DOORS
 2790 Northwest 104th Court
 Miami, FL 33172-2175
 Phone (305) 599-8093
 Fax (305) 592-4671

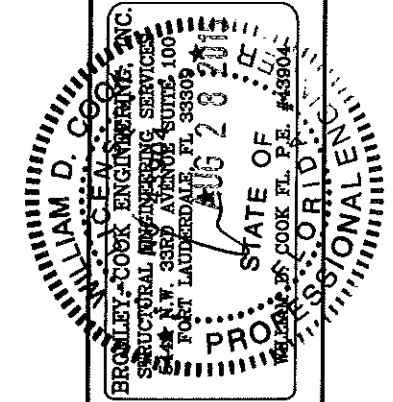
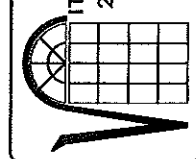

PRODUCT:
 EKU-53
 IMPACT DOORS
 HIGH LOAD

REVISIONS	
No.	DATE BY DESCRIPTION

DATE: 10/16/2014
 SCALE: AS NOTED
 DWG. BY: LA FIN
 CHK. BY:

DRAWING No.:
 FN-EKU53-FD
 SHEET: 14 OF 15

BILL OF MATERIALS

ITEM	PART No.	QUANTITY	DESCRIPTION	MATERIAL	LOCATION	MANUFACTURER
1	7011	4	FRAME HEAD/JAMB/RESIDENTIAL SILL	AL.AL. -6060-T5	WINDOW FRAME	PROFILATI SpA
1A	7012	4	FRAME HEAD/JAMB/RESIDENTIAL SILL	AL.AL. -6060-T5	WINDOW FRAME	PROFILATI SpA
1B	17948	4	FRAME HEAD/JAMB/RESIDENTIAL SILL	AL.AL. -6063-T5	WINDOW FRAME	PROFILATI SpA
1C	17949	4	FRAME HEAD/JAMB/RESIDENTIAL SILL	AL.AL. -6063-T5	WINDOW FRAME	PROFILATI SpA
2	16012	4	PANEL HEAD/JAMB/SILL	AL.AL. -6060-T5	WINDOW FRAME	PROFILATI SpA
2A	16013	4	PANEL HEAD/JAMB/SILL	AL.AL. -6063-T5	WINDOW FRAME	PROFILATI SpA
2B	Z19678	4	PANEL HEAD/JAMB/SILL	AL.AL. -6063-T5	WINDOW FRAME	PROFILATI SpA
2C	18853	4	PANEL HEAD/JAMB/SILL	AL.AL. -6063-T5	WINDOW FRAME	PROFILATI SpA
2D	16012-R	4	PANEL HEAD/JAMB/SILL	AL.AL. -6063-T5	WINDOW FRAME	PROFILATI SpA
2E	18853-R	4	PANEL HEAD/JAMB/SILL	AL.AL. -6063-T5	WINDOW FRAME	PROFILATI SpA
2F	16013-R	4	PANEL HEAD/JAMB/SILL	AL.AL. -6063-T5	WINDOW FRAME	PROFILATI SpA
2G	16013-S	4	PANEL HEAD/JAMB/SILL	AL.AL. -6063-T5	WINDOW FRAME	PROFILATI SpA
3	Z16014	1	ASTRAGAL	AL.AL. -6060-T5	INACTIVE LEAF PANEL JAMB	PROFILATI SpA
4	4195	4/VENT	GLAZING BEAD	AL.AL. -6060-T5	PANEL PERIMETER	PROFILATI SpA
5	NOT USED					
6	A8221	6/VENT	4" BUTTHINGES	AL.AL. -6060-T5	PANEL AND FRAME JAMBS	MASTER
6A	160/12	6/VENT	4" BUTTHINGES	AL.AL. -6060-T5	PANEL AND FRAME JAMBS	CASALI
7	N/A	2 EA. LITE OF GLASS	1/4" X 1/2" X 3" LG. SETTING BLOCK	EXTRUDED SILICONE	@ 6" FROM ENDS	GENERIC
9	0409	1 EA. CORNER	FRAME CORNER KEY	CAST ALUMINUM	FRAME CORNERS	MONTICELLI
10	5004	1 EA. CORNER	PANEL CORNER KEY	CAST ALUMINUM	PANEL CORNERS	MONTICELLI
10A	001	1 EA. CORNER	PANEL CORNER KEY	EXT. ALUMINUM	PANEL CORNERS	PROFILATI SpA
10B	002	1 EA. CORNER	PANEL CORNER KEY	EXT. ALUMINUM	PANEL CORNERS	PROFILATI SpA
12	SERIES 800	1/VENT	OPERATING HANDLE	ALUMINUM	EACH PANEL JAMB	PASINI
13	1025	2	TRANSMISSION MOVEMENT DEVISE	ZAMA/S.S.	PANEL JAMB ASTRAGAL SIDE ONLY	GSG
14	1286		5-POINT LOCKING SYSTEM	S.S.	ACTIVE PANEL	AMESBURY
15	FB-1300-20-SS	2	FLUSH BOLT	S.S.	ACTIVE PANEL	SULLIVAN
16	4031	AS SHOWN	MUSHROOM HEAD AND KEEPERS	S.S./ALUMINUM	PANEL JAMB AT TOP & BOTTOM	GSG/LAFIN
16A	CD-MPK-100-SS		MULTIPOINT KEEPER KIT	S.S./ALUMINUM	PANEL JAMB AT TOP & BOTTOM	SULLIVAN
17	2666	AS REQ'D.	WEATHERSTRIP GASKET	EPDM	FRAME JAMB/ASTRAGAL/FRAME PANEL	PROFILATI SpA
18	002/009	AS REQ'D.	WEDGE GASKET	EPDM	PANEL GLAZING PERIM. (INTERIOR)	PROFILATI SpA
19	----	2/EACH	# 10 x 2 1/2" FH.SMS. (ASSEMBLY)	PLATED STEEL	FLUSHBOLT STRIKE PLATE	----
20	----	SEE ELEV.	# 10 x 2" FH.SMS. (ASSEMBLY)	PLATED STEEL	ASTRAGAL (SINGLE ROW)	----
22	----	2 EA. CORNER	#14 X 3/4" FH. SMS. (PANEL ASS'Y)	PLATED STEEL	PANEL CORNERS	----
23	895/995	CONTINUOUS	STRUCTURAL SILICONE	SILICONE	PERIMETER GLASS TO METAL	PECORA OR DOW CORNING
25	CD.100.BK	AS REQ'D.	FRAME INSERT	ALLUM/NYLON	FRAME PERIMETER (SINGLE ROW)	SULLIVAN
26	SDG.SP.316	AS REQ'D.	STRIKE PLATE	S.S.	ALONGSIDE FRAME (WHERE LOCK MEETS)	SULLIVAN
27	092109	4/VENT	GLAZING BEAD	AL.AL. -6060-T5	PANEL PERIMETER	PROFILATI SpA
28	4293	4/VENT	GLAZING BEAD	AL.AL. -6060-T5	PANEL PERIMETER	PROFILATI SpA
29	2167/2168	2	FLUSH BOLT	ZAMA	INACTIVE PANEL	GSG

NOT USED: 5
8 21
11 24

LA FINESTRA, L.C.
 ITALIAN WINDOWS & DOORS
 2790 Northwest 104th Court
 Miami, FL 33172-2175
 Phone (305) 599-8093
 Fax (305) 592-4671

WILLIAM D. COPE ENGINEERING, INC.
 STRUCTURAL ENGINEERING SERVICES
 4440 N.W. 88th Avenue Suite 100
 Fort Lauderdale, FL 33308
 9/28/2015
 WILLIAM D. COPE P.O.P.E. #49904

PRODUCT:
EKU-53
IMPACT DOORS
HIGH LOAD

REVISIONS	No.	DATE	BY	DESCRIPTION

DATE: 10/16/2014
 SCALE: AS NOTED
 DWG. BY: LA FIN
 CHK. BY:
 DRAWING No.:
 FN-EKU53-FD
 SHEET: 15 OF 15